

Desoutter



Industrial TOOLS



QUALITY CONTROL Measurement System

Optimize Tool Performance
Reduce Quality Cost
Full Data Traceability

More Than Productivity



QUALITY ASSURANCE TECHNIQUES

Statistical quality assurance techniques help organizations to achieve over 30% defect reduction annually. They reflect a growing trend throughout the industry to become more quantitative about quality.

Activities to implement start from the qualification of your assembly tools in inventory, and the regular tests of their performance over their lifetime.

But over the simple measurement of Power Tools performances, Quality Assurance allows a continuous improvement of processes.

USING SIX SIGMA FOR PROCESS IMPROVEMENT (DMAIC)

- DEFINE: Set the goal
- MEASURE: Define the metrics
- ANALYZE: Measure where you go
- IMPROVE: Improve Processes while you go
- CONTROL: Act immediately if going on the wrong path

Measure and Analyze are the main added value of the range exposed in following pages.

Based on your Control Plan, the different solutions we provide in Measurement Techniques allow you to:

- ▀ Take control of the Capability and repeatability of Assembly tools from their reception in the factory, and make it sustainable and traceable with Machine Capability Tests and Calibration reports.
- ▀ Qualify the selected tools for specific operations in regards to the periodical tests performed.
- ▀ Measure in SPC the output of production and get clear guidance to implement preventive maintenance or detect a process deviation on critical operations.
- ▀ Enable documentation of your tightening operations from engineering phase to quality audits.

As a manufacturer of Industrial Tools, measurement systems, and service provider Desoutter is your partner to make your investment sustainable and cost effective.

DATA ANALYZER

This generation of Delta analyzer is the compact portable solution to monitor all types of production tools at just 500g. Combined with standard Desoutter DRT, PST, FCT or DST transducers it's capable of calibrating pulse tools, electric nutrunners or torque wrenches. Divided into three models for Torque measurement only (DELTA 1D), Torque & Angle (Delta 6D) and capable of residual torque check and production strategy with Q-AUDIT (Delta 7D).

- Display Large color screen shows clear test results, Torque&Angle curves. Real time statistics, Tools description and Routes.



MAIN FUNCTION

	Delta 1D	Delta 6D	Delta 7D
Transducer			
Connection to DRT4, DRT5, DST	✓	✓	✓
Connection to CMD, GSE transducers	✓	Through optional analog/digital adapter	✓
Connection to Q-AUDIT			✓
On board functionality			
Wrench Test	✓	✓	✓
Nutrunner Test	✓	✓	✓
Pulse Tool Test	✓	✓	✓
Tools	1	1000	1000
PSet		1000	1000
Integrated Statistic	Min, Max Avg	Cm, Cmk (ISO, NF and CNOMO standards)	Cm, Cmk (ISO, NF and CNOMO standards) + SPC
Angle		✓	✓
Residual Check Strategy			✓
Production Strategy			✓
Results	1000	5000	5000
Curve	10	10	10
CVI autocalibration		✓	✓
External Barcode connectivity		✓	✓
Embedded Barcode			✓

DELTA

MAIN FUNCTION

- Connectivity Ethernet and USB port for Delta QC software communication and RS232 for CVI II, CVIC II and CVI3 calibration or barcode reader.



- Transducer Standard Desoutter connector for digital transducers. Analog CMD and GSE transducers connection through an adapter.



- Power Li-Ion high capacity battery of 16 hours of autonomy or external power supply.



- Barcode (Delta 7D) Embedded Barcode for automatic Pset selection or VIN traceability

DELTA 1D

DELTA 1D is a torque measurement ideal for torque wrench or pulse tool test together with DRT or PST transducers. Delta 1D doesn't require any programming, it's ready to test the selected tool showing in real time Mins, Max and Average. Complete results and XLS reports are available to be exported from Delta QC Free version software.



DELTA 6D

DELTA 6D reads Angle from DRT transducer, ideal to test advanced electric nutrunner T&A strategies. DELTA 6D introduces Tool and PSet and definition with Route management, Statistic (ISO, CNOMO or NF standards), Curve and serial communication to CVI controller or Barcode. SPC analysis, curve overlay and off-line programming are available in combination with Delta QC Licensed version.



DELTA 7D

DELTA 7D combines all DELTA 6D features with DWTA wrench communication for Residual Torque check and production available with Torque plus Angle strategy. Thanks to the new joint analysis strategy the Delta 7D in combination with Q-AUDIT becomes the perfect measurement instrument to characterise the real joint in the line, a key feature to:

- find real joint yield point
- set the production tightening tool with the correct torque and angle values increasing the quality in the overall production process.



Q-AUDIT - WRENCH

PRODUCTION & QUALITY STRATEGIES: In combination with Delta 7D, the torque and angle wrench for residual automatic torque check and Joint analysis with Yield point detection.

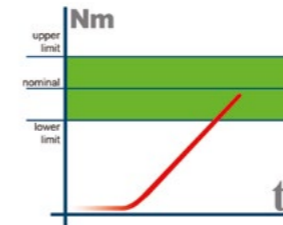

Tightening within torque limits

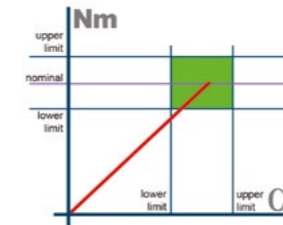

Tightening within torque and angle limits (tightening to a window)

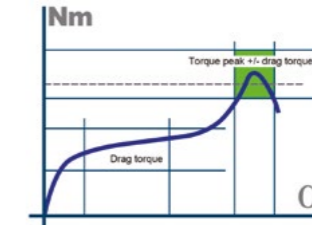

Prevailing torque automatic compensation

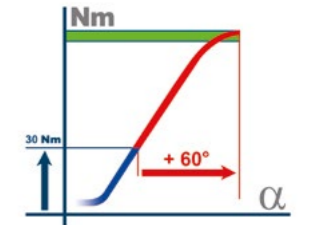

Tightening with torque and additional angle rotation (torque + angle)



MODEL	PART NUMBER	POWER REQUIREMENTS		DIMENSIONS						WEIGHT	
		BATTERY LIFE	CHARGER	DEPTH	WIDTH		HEIGHT		Kg	lb	
		hours	volt	mm	in.	mm	in.	mm	in.		
DELTA 1D	615 935 101 0	16	110/240	45	1.77	95	3.74	192	7.56	0.5	1.1
DELTA 6D	615 935 102 0	16	110/240	45	1.77	95	3.74	192	7.56	0.5	1.1
DELTA 7D	615 935 103 0	16	110/240	45	1.77	95	3.74	192	7.56	0.5	1.1

All models are supplied with box including Battery, Power Supplier and Delta QC Free Version

ACCESSORIES INCLUDED

ITEM	PART NUMBER
Delta Battery	615 936 142 0
Universal Power Supplier	615 936 143 0

OPTIONAL ACCESSORIES

ITEM	PART NUMBER
Rubber Protection	615 936 141 0
Digital 10 pins Cable 2m	615 917 430 0
Digital 10 pins Spiral Cable 2m	615 917 432 0
Digital 10 pins Cable 5m	615 917 433 0
CMD & ST 4000 Adapter	615 917 671 0
CMD 5000 Adapter	615 917 672 0
Delta Neck Holder	615 936 530 0

ITEM	PART NUMBER
RS232 Adapter	615 917 670 0
GSE 2500 Adapter	615 917 674 0
GSE 8500T Adapter	615 917 675 0
GSE 8500T/A Adapter	615 917 676 0
Analog 19 pins Adapter	615 935 175 0
Delta Demo Case (Empty)	615 936 140 0

SOFTWARE

Delta QC Licensed 1 User	615 927 651 0
Delta QC Licensed 5 User	615 927 652 0
Delta QC Advanced 1 User	615 927 653 0
Delta QC Advanced 5 User	615 927 654 0

MODEL	PART NUMBER	RANGE		ANGLE	DRIVE		INCLUDED RATCHET	LENGTH		WEIGHT	
		Nm	ft.lb		mm	in.		in.	mm	in.	Kg
Q-AUDIT 30	615 221 040 0	3-30	2.21-22.13	YES	9X12	0.35X0.47	3/8	405	15.9	0.765	1.686
Q-AUDIT 150	615 221 041 0	15-150	11.06-110.6	YES	14X18	0.55X0.70	3/8	420.5	16.55	1.020	2.248
Q-AUDIT 350	615 221 042 0	35-350	25.81-258.1	YES	14X18	0.55X0.70	3/8	697	27.44	2.168	4.779

WRT - WIRELESS ROTARY TRANSDUCER

The WRT is a means of **auditing not only the tools** (click-wrenches, slip-wrenches, nutrunners or Pulse tools*) but also **the assembly process, providing a detailed analysis of torque and angle information.**

With the WRT you can:

- Manual & Automatic Calibration (Automatic Adjustment) with CONNECT Smart hub
- SPC (Statistical Process Control)
- CM / CMK
- Demo mode



MODEL	A	B	C	D	E	F	G	H
	mm	mm	mm	mm	mm	mm	mm	mm
WRT4-HEX1/4	115.8	45	138.3	33.8	61.5	20.5	25.5	20
WRT10-HEX1/4	115.8	45	138.3	33.8	61.5	20.5	25.5	20
WRT20-HEX1/4	115.8	45	138.3	33.8	61.5	20.5	25.5	20
WRT25-SQ3/8	82.6	45	138.3	12.1	61.5	9	11	20
WRT75-SQ3/8	82.6	45	138.3	12.1	61.5	9	11	20
WRT180-SQ1/2	90.5	45	141.8	17	61.5	12	15.2	22.5
WRT500-SQ3/4	106	56	151.9	24.6	68	13.4	23	28

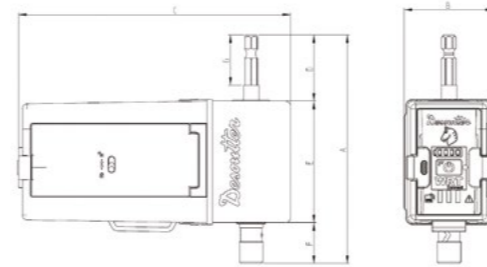

WRT4-Hex1/4, WRT10-Hex1/4, WRT20-Hex1/4

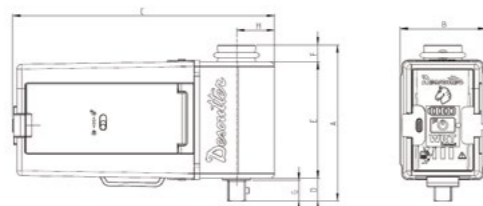

WRT25-Sq3/8, WRT75-Sq3/8, WRT180-Sq1/2

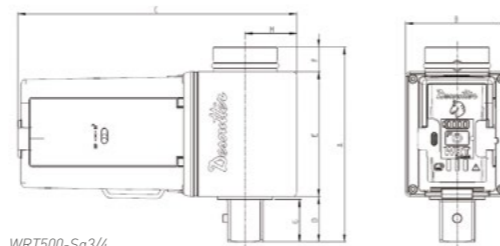

WRT500-Sq3/4

PIC	MODEL	PART NUMBER	OUTPUT DRIVE	TORQUE				WEIGHT	
				MIN.	MAX.*	MIN.	MAX.*	gr	lb
A	WRT4-HEX1/4	615 221 051 0	1/4	Nm	Nm	ft. lb	ft. lb	483.5	1.065
A	WRT10-HEX1/4	615 221 052 0	1/4	0.4	4	0.36	3.6	484.7	1.068
A	WRT20-HEX1/4	615 221 053 0	1/4	1	10	0.88	8.8	463.2	1.02
B	WRT25-SQ3/8	615 221 054 0	3/8	2	20	1.47	14.7	486.4	1.07
B	WRT75-SQ3/8	615 221 055 0	3/8	2.5	25	1.84	18.4	491.4	1.08
C	WRT180-SQ1/2	615 221 056 0	1/2	7.5	75	5.53	55.3	599.7	1.32
D	WRT500-SQ3/4	615 221 057 0	3/4	18	180	13.27	132.7	1094	2.41

*With Pulse tools, the WRT shall not be used over 50% of the maximum torque.

ACCESSORIES



ACCESSORIES INCLUDED

ITEM	REFERENCES
3	WRT Battery 615 936 531 0

OPTIONAL ACCESSORIES

ITEM	REFERENCES
1	WRT 2x Adapters 615 936 534 0
2	QA Charger 615 936 461 0
3	WRT Battery 615 936 531 0
4	WRT anti-rotation holder ¹ 615 936 535 0
5	CVI KEY ² 615 927 676 0

¹For angle tools with compatible sizes (tool diameter less than 43 mm, such as EABC 32-410, EABC 50-450, EABC 60-370, EABC 17-800-4Q, EABC 24-500-4Q, ELS330-300-A, etc.).

²The WRT Web User Interface uses a role-based authorization system. User permissions depend on the role assigned to the user with the CVI KEY. Without it, you will only have access to "Demo mode". To create an operation (tool & Pset), you need to enter your CVI KEY.

INTUITIVE WEB USER INTERFACE

- View the results with the device of your choice: computer, tablet or smartphone !
- The web user interface gives access to the result data base, curves, live results and the data download facility.

WRT offers three different ways to access its web user interface:

- EMBEDDED ACCESS POINT (DHCP) / WEB:** WRT hosts an embedded access point. You can update network settings directly through the intuitive Web User Interface and choose between static and DHCP methods for IP address allocation. It's ideal for scenarios where simplicity and self-contained connectivity are paramount.
- INFRASTRUCTURE MODE:** In this mode, WRT seamlessly integrates into your existing factory network. It's perfect for environments where additional Wi-Fi networks are undesirable or impractical.
- BY CABLE:** Use the cable for your first connection - it's a one-time requirement - then this old-school approach is also possible from this point forward..

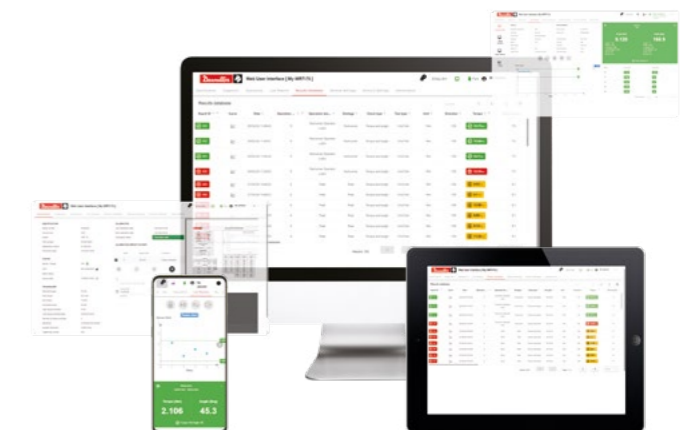

DRT - DIGITAL ROTARY TRANSDUCERS

The DRT4 rotary transducer series are designed to measure torque output (Only) of any non-impact assembly tool, directly on your application in dynamic mode.



MODEL	PART NUMBER	TORQUE RANGE		OUTPUT
		Nm	ft. lb	
DRT 4 H 2	615 165 209 0	0.2 - 2	0.15 - 1.5	HEX 1/4"
DRT 4 H 5	615 165 210 0	0.5 - 5	0.37 - 3.7	HEX 1/4"
DRT 4 H 20	615 165 211 0	2 - 20	1.47 - 14.7	HEX 1/4"
DRT 4 SQ 20	615 165 212 0	2 - 20	1.47 - 14.7	SQ 1/4"
DRT 4 SQ 25	615 165 213 0	2.5 - 25	1.84 - 18.4	SQ 3/8"
DRT 4 SQ 75	615 165 214 0	7.5 - 75	5.53 - 55.3	SQ 3/8"
DRT 4 SQ 180	615 165 215 0	18 - 180	13.2 - 132	SQ 1/2"
DRT 4 SQ 500	615 165 216 0	50 - 500	36.8 - 368	SQ 3/4"
DRT 4 SQ 1400	615 165 217 0	140 - 1400	103.2 - 1032	SQ 1"
DRT 4 SQ 3000	615 165 536 0	300 - 3000	221.1 - 2211	SQ 1-1/2"
DRT 4 SQ 5000	615 165 540 0	500 - 5000	368.5 - 3685	SQ 1-1/2"
DRT4 SQ 10000	615 935 164 0	1000 - 10000	736.6 - 7375	SQ 1-1/2"

Note: The DRT shall not be used with pulse tools over 50 % of the transducer nominal torque

FEATURES

- Torque range from 0.2 to 10000 Nm (0.15 to 7375 ft.lb).
- Strain gauges transducer : - sensitivity 2mV/V - accuracy +/-0.35% of max. torque.
- Built-in smart chip memory with calibration features : - type of transducer - sensitivity nominal load - serial number.

BENEFITS

- Automatic recognition thanks to internal memory chip storing main data values eliminating any setting mistakes and time losses.
- High reliability due to immunity from external noise thanks to digital communication.
- Communication to data analyzer not sensitive to the cable length.
- Long life durability thanks to industrial design from transducer to housing.

TRANSDUCER CABLES

MODEL	PART NUMBER	OUTPUT
2M (78.7") - 10 PINS	615 917 430 0	For DRT / PST / DSTxs / FCT - all Delta Models
2M (78.7") SPIRAL - 10 PINS	615 917 432 0	For DRT / PST / DSTxs / FCT - all Delta Models
5M (196.8") - 10 PINS	615 917 433 0	For DRT / PST / DSTxs / FCT - all Delta Models

DIGITAL ROTARY TRANSDUCERS & ACCESSORIES

The DRT5 series associated with a Delta 6D or Delta 7D are including an Angle measurement encoder to allow both Torque AND Angle quality controls (preferred series in case you are using Angle strategies and/or monitoring).



MODEL	PART NUMBER	TORQUE RANGE		OUTPUT
		Nm	ft. lb	
DRT 5 H 2	615 165 218 0	0.2 - 2	0.15 - 1.5	HEX 1/4"
DRT 5 H 5	615 165 219 0	0.5 - 5	0.37 - 3.7	HEX 1/4"
DRT 5 H 20	615 165 220 0	2 - 20	1.47 - 14.7	HEX 1/4"
DRT 5 SQ 20	615 165 221 0	2 - 20	1.47 - 14.7	SQ 1/4"
DRT 5 SQ 25	615 165 222 0	2.5 - 25	1.84 - 18.4	SQ 3/8"
DRT 5 SQ 75	615 165 223 0	7.5 - 75	5.53 - 55.3	SQ 3/8"
DRT 5 SQ 180	615 165 224 0	18 - 180	13.2 - 132	SQ 1/2"
DRT 5 SQ 500	615 165 225 0	50 - 500	36.8 - 368	SQ 3/4"
DRT 5 SQ 1400	615 165 226 0	140 - 1400	103.2 - 1032	SQ 1"
DRT 5 SQ 5000	615 165 780 0	500 - 5000	368.5 - 3685	SQ 1-1/2"

FEATURES

- Torque range from 0.2 to 5000 Nm (0.15 to 3685 ft.lb).
- Angle counting system 0.35° resolution.
- Strain gauges transducer : - sensitivity 2mV/V - accuracy +/-0.35% of max. torque.
- Built-in smart chip memory with calibration features : - type of transducer - sensitivity nominal load - serial number.

SAME SIZE FOR TORQUE OR TORQUE & ANGLE TRANSDUCER

OUTPUT	A		B		C		E		H		F		G	
	Nm	in.	Nm	in.	Nm	in.	Nm	in.	Nm	in.	Nm	in.	Nm	in.
HEX 1/4"	116	4.56	31	1.22	71.9	2.83	56	2.2	15.5	0.61	39	1.53	25.5	1
SQ 1/4"	71.5	2.81	31	1.22	71.9	2.83	56	2.2	15.5	0.61	6	0.24		
SQ 3/8"	77	3.03	31	1.22	71.9	2.83	56	2.2	15.5	0.61	8	0.31		
SQ 1/2"	87	3.42	42	1.65	82.9	3.26	58	2.28	21	0.83	12	0.47		
SQ 3/4"	106	4.17	52	2.05	92.9	3.66	66	2.60	26	1.02	21	0.83		
SQ 1"	125	4.92	65	2.56	104.9	4.13	73	2.87	32.5	1.28	29	1.14		
SQ 1-1/2"	165	6.5	106	4.17	148.5	5.85	88	3.46	53	2.09	35.2	1.39		

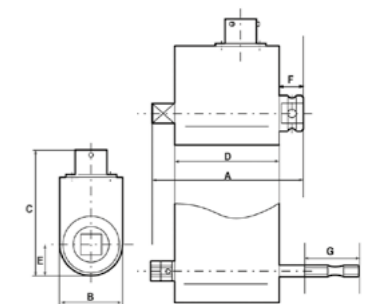

PST - PULSE STATIC TRANSDUCER

Designed for testing hand wrenches, click wrenches, Pneumatic Pulse tools and electric nutrunners, the Pulse Static Transducer is the ideal solution to provide a periodic and static mean of control for audit at the station and will cover all your assembly tools in the production area.

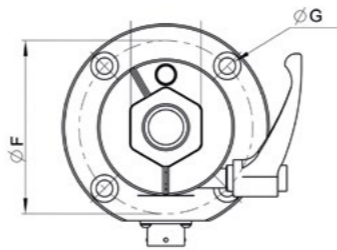
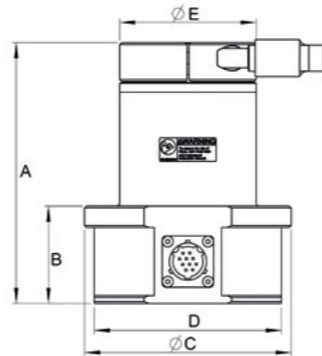
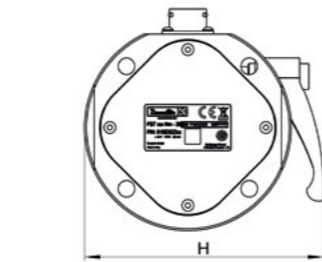

(reminder: the joint simulator is required accessory in the case of a shut-off pulse or nutrunner tool test).

FEATURES

- Torque accuracy +/-0.35% of torque max.
- Built-in smart chip memory with calibration features:
 - type of transducer - sensitivity nominal load - serial number
- Lever to clamp the Joint simulator firmly for impulse tools
- Recommended for Pulse tools

MODEL	PART NUMBER	TORQUE RANGE		DIMENSIONS (MM)								INPUT		WEIGHT	
		Nm	ft.lb	A	B	C	D	E	F	G	H			Kg	lb
PST 2 NM - 13	615 935 220 0	0.2 - 2	0.15-1.5	83	39	80	69	45	64	4x Ø 6.5	/	Sq 1/2"	1.4	3.1	
PST 5 NM - 13	615 935 221 0	0.5 - 5	0.37 - 3.7	83	39	80	69	45	64	4x Ø 6.5	/	Sq 1/2"	1.4	3.1	
PST 10 NM - 13	615 935 222 0	1-10	0.74-7.4	83	39	80	69	45	64	4x Ø 6.5	/	Sq 1/2"	1.4	3.1	
PST 25 NM - 36	615 935 223 0	2.5-25	1.8-18	134	50	106	96	70	89	4x Ø 8.5	123	Hex 36	4	8.8	
PST 50 NM - 36	615 935 224 0	5-50	3.7-37	134	50	106	96	70	89	4x Ø 8.5	123	Hex 36	4	8.8	
PST 100 NM - 36	615 935 225 0	10-100	7.4-74	134	50	106	96	70	89	4x Ø 8.5	123	Hex 36	4	8.8	
PST 250 NM - 36	615 935 226 0	25-250	18.4-184	134	50	106	96	70	89	4x Ø 8.5	123	Hex 36	4	8.8	
PST 500 NM - 50	615 935 227 0	50 - 500	36.9-369	170	50	148	136	108	125	6x Ø 8.5	180	Hex 50	10.1	22.3	
PST 1000 NM - 50	615 935 228 0	100-1000	73.8-738	170	50	148	136	108	125	6x Ø 8.5	180	Hex 50	10.1	22.3	
PST 2000 NM - 50	615 935 229 0	200-2000	147.5-1475	170	50	148	136	108	125	6x Ø 8.5	180	Hex 50	10.1	22.3	

JOINT SIMULATOR

A wide range of mechanical joint simulators are available to reproduce the joint behavior; installing the joint simulator on a transducer allows you to test a tool in the same repeatable working conditions. Each joint simulator reproduces a specific stiffness as described in its torque/angle characteristics. For each capacity, there are two versions: one reproducing a softer joint and one reproducing a harder joint.

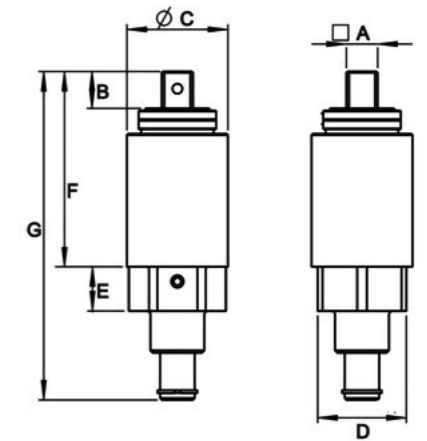

MODEL	PART NUMBER	COLOR	DIMENSIONS (MM)						
			Nm	A	B	C	D	E	F
DJS FOR DST AND PST 2 NM SOFT	615 165 529 0	YW - YW	HEX 1/4"	14	24	SQ. 1/2"	8	50	71,5
DJS FOR DST AND PST 2 NM HARD	615 165 530 0	YW - BK	HEX 1/4"	14	24	SQ. 1/2"	8	50	71,5
DJS FOR DST AND PST 5 NM SOFT	615 165 531 0	GR - YW	HEX 1/4"	14	24	SQ. 1/2"	8	50	71,5
DJS FOR DST AND PST 5 NM HARD	615 165 571 0	GR - BK	HEX 1/4"	14	24	SQ. 1/2"	8	50	71,5
DJS FOR PST 10 NM SOFT	615 936 377 0	RD - YW	HEX 1/4"	14	24	SQ. 1/2"	8	50	71,5
DJS FOR PST 10 NM HARD	615 936 378 0	RD - BK	HEX 1/4"	14	24	SQ. 1/2"	8	50	71,5
DJS FOR PST 25 NM SOFT	615 936 379 0	RD - YW	SQ. 3/8"	11	34	HEX 36	16,5	70	120,5
DJS FOR PST 25 NM HARD	615 936 380 0	RD - BK	SQ. 3/8"	11	34	HEX 36	16,5	70	120,5
DJS FOR PST 50 NM SOFT	615 936 381 0	BL - YW	SQ. 1/2"	15	41	HEX 36	18	84	133,5
DJS FOR PST 50 NM HARD	615 936 382 0	BL - BK	SQ. 1/2"	15	41	HEX 36	18	84	133,5
DJS FOR PST 100 NM SOFT	615 936 365 0	VL - YW	SQ. 1/2"	15	41	HEX 36	18	84	133,5
DJS FOR PST 100 NM HARD	615 936 366 0	VL - BK	SQ. 1/2"	15	41	HEX 36	18	84	133,5
DJS FOR PST 250 NM SOFT	615 936 384 0	GY - YW	SQ. 1/2"	15	41	HEX 36	18	84	133,5
DJS FOR PST 250 NM HARD	615 936 385 0	GY - BK	SQ. 1/2"	15	41	HEX 36	18	84	133,5
DJS FOR PST 500 NM SOFT	615 936 369 0	BK - YW	SQ. 3/4"	22	59	HEX 50	30	141	224
DJS FOR PST 500 NM HARD	615 936 370 0	BK - BK	SQ. 3/4"	22	59	HEX 50	30	141	224
DJS FOR PST 1000 NM	615 936 386 0	NO COLOR	SQ. 1"	28	90	HEX 50	30	179	273
DJS FOR PST 2000 NM	615 936 393 0	NO COLOR	SQ. 1 1/2"	38	138	HEX 50	30	168.2	218.2

ADAPTERS & COUPLINGS

MODEL	PART NUMBER	MODEL	PART NUMBER	MODEL	PART NUMBER
Accessories for Static transducers & Joint simulators					
3/4" M-1/4" F	615 397 205 0	1/2" M-3/8" F	615 936 111 0	HEX 1/4" M-1/4" F	615 936 118 0
3/4" M-3/8" F	615 397 206 0	1/2" F-3/8" F	615 936 112 0	HEX 1/4" M-3/8" F	615 936 119 0
1" M-1/2" F	615 397 207 0	1/2" M-1/2" F	615 936 113 0	1" F-3/4" F	615 936 126 0
1" 1/4 M-1/2" F	615 397 208 0	1" 1/4 M-3/4" F	615 936 114 0	3/4" F-1/2" F	615 936 130 0
1" 1/4 M-3/4" F	615 397 209 0	1/4" F-3/8" F	615 936 115 0	1" 1/2 F-1" 1/2 F	615 936 436 0
1/4" F-1/4" F	615 397 210 0	1" 1/4 M-1" F	615 936 116 0	1/2" F-1/2" F	615 165 573 0
3/8" F-3/8" F	615 397 211 0	1" F-1" F	615 936 117 0	3/4" F-3/4" F	615 165 576 0
1" M-3/4" F	615 936 110 0				

Direct adapter for Non shut-off pulse tools and click wrenches (without DJS).

MODEL	PART NUMBER
HEX 36 M-3/8" F	615 936 398 0
HEX 36 M-1/2" F	615 936 399 0
HEX 50 M-1/2" F	615 936 431 0
HEX 50 M-3/4" F	615 936 432 0
HEX 50 M-1" F	615 936 433 0
HEX 1/4" M-1/4" F	615 936 118 0
HEX 1/4" M-3/8" F	615 936 119 0

DSTxs SERIES - DIGITAL STATIC TRANSDUCERS



Ideal for Nanodrivers.

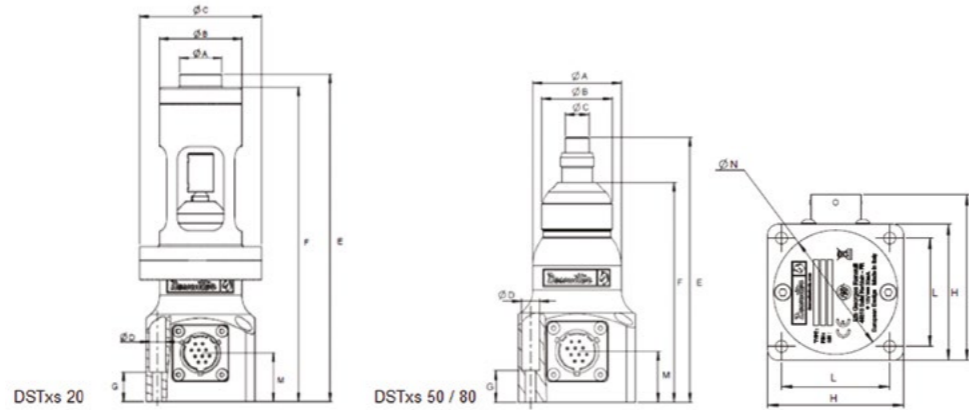

FEATURES

- Accuracy from 10% to 100% of the nominal torque : +/-0,5% FSD (Full Scale Deviation) - Overload at 120% of nominal capacity.
- Stability of Zero offset with temperature: $\leq \pm 0.1\% \text{ FSD}/^\circ\text{C}$ - Operating temperature: 5 to 40°C.
- Built-in memory with calibration features: Serial Number, Transducer Type, Sensitivity, Nominal Load, Calibration / Maintenance date, Tightening counter, Damage limit.

BENEFITS

- Automatic recognition thanks to internal memory chip storing main data values eliminating any setting mistakes and time losses.
- High reliability due to immunity from external noise thanks to digital communication.
- Communication to data analyzer not sensitive to the cable length.

MODEL	PART NUMBER	TORQUE RANGE		SQUARE DRIVE	DIMENSIONS (MM)										WEIGHT	
		cNm	in.lbs		$\varnothing A$	$\varnothing B$	$\varnothing C$	L		H		Kg	lb			
DSTXS 20 cNM	615 935 220 0	2-20	0.17-1.77	dia 3mm	20	0.787	39	1.535	58	2.283	41	1.614	51.5	2.027	0.56	1.2
DSTXS 50 cNM	615 935 221 0	5-50	0.44-4.42	Hex 1/4	39	1.535	32	1.259	10.5	0.413	41	1.614	51.5	2.027	0.42	0.9
DSTXS 80 cNM	615 935 222 0	8-80	0.70-7.08	Hex 1/4	39	1.535	32	1.259	10.5	0.413	41	1.614	51.5	2.027	0.42	0.9

JOINT SIMULATOR KITS

MODEL	PART NUMBER	JOINTS COVERED				ADAPTER	SCREW SIZE
		Hard / mini	Soft / mini	Hard / max	Soft / max		
DJSxs 20	615 936 445 0	2-6 cNM	2-6 cNM	20 cNM	20 cNM	DIA 3MM	M2
DJSxs 50	615 936 446 0	5-15 cNM	5-15 cNM	50 cNM	50 cNM	HEX 1/4	M2 & M3
DJSxs 80	615 936 447 0	8-24 cNM	8-24 cNM	80 cNM	80 cNM	HEX 1/4	M3

ITEM	CONTENT OF THE DJS KIT SUITCASE
1	DJSxs assembly - min. torque - Soft joint x1
2	Spare compression spacer - min. torque - Soft x4
3	Spare compression spacer - min. torque - Hard x1
4	DJSxs assembly - min. torque - Hard joint x1
5	DJSxs assembly - nominal torque - Hard joint x1
6	Spare compression spacer - nominal torque - Hard joint x1
7	Spare compression spacer - nominal torque - Soft joint x4
8	DJSxs assembly - nominal torque - Soft joint x1
9	DJSxs20 assembly - min./nominal torque - Soft joint - spacer for DSTxs adapter
10	DJSxs20 assembly - min./nominal torque - Hard - spacer for DSTxs adapter

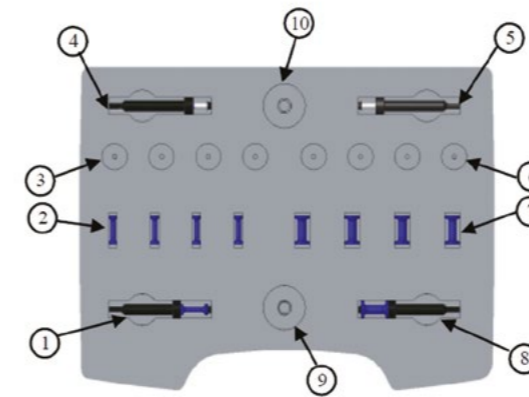

FCT SERIES - CLAMP FORCE TRANSDUCERS

The purpose of the FCT is to measure the repeatability of a pulse tool in achieving a constant tension independently from the friction effects and detect a deviation over time. Delta 6D/7D can display both the load and equivalent torque.



Ideal for Pulse tools.

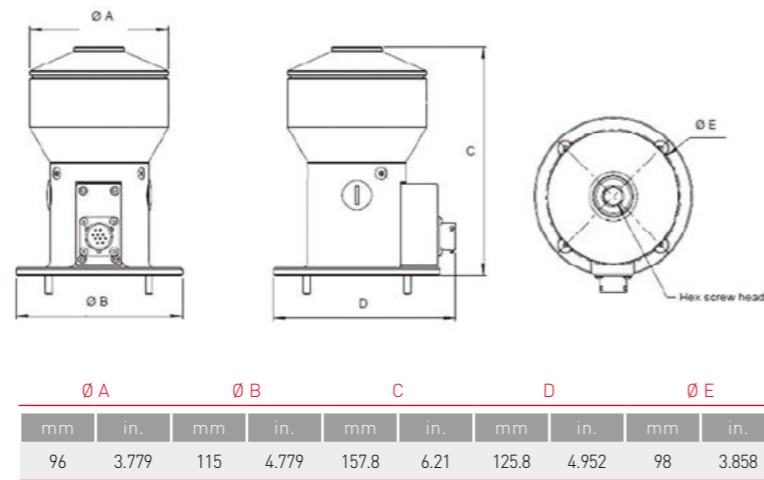

ACCESSORIES

ACCESSORIES INCLUDED

	ITEM		PART NUMBER
FCT30	1	FCT30 Screw	615 936 484 0
	2	Sleeve Drive Sockets 3/8" - 13mm	615 811 781 0
FCT60	1	FCT60 Screw	615 936 485 0
	2	Sleeve Drive Sockets 3/8" - 18mm	615 811 784 0



Oil recommended to fill the oil bath: 75W-90.

FEATURES

- Accuracy +/-0,5% of Applied Force Reading Value.
- Built-in Load Cell.
- Used with Delta xD data collectors and cables.
- 12 hours autonomy with the Delta 6D/7D.
- Allows a display of both Clamping Force and Torque (K factor).
- Up to 2000 Hz filter selection.
- With Delta 6D/7D, RS-232 interface to download readings.
- Large screen and easy to use menus with Delta 6D/7D.
- Supplied with screw kit and 3/8" socket SW13.

BENEFITS

- Measures the repeatability of pulse tools to achieve a target clamping force.
- By measuring the clamp force instead of the torque delivered, the adverse effects of adding an in-line torque transducer are eliminated.
- As most design offices specify a clamping force, measuring the actual clamping force allows to eliminate the uncertainty linked to the translation in torque of a clamping value.

MODEL	PART NUMBER	TORQUE RANGE		LOAD RANGE		OVERLOAD				WEIGHT	
		Nm	ft.lbs	N	lbf	FORCE		TORQUE		Kg	lb
						N	lbf	Nm	ft.lbs		
FCT30	615 935 249 0	10-30	7.30-22.13	1800-18000	405-4050	23400	5260	39	28.7	2.4	5.3
FCT60	615 935 250 0	20-60	14.75-44.25	2700-27000	607-6070	35100	7890	78	57.5	2.4	5.3

CALIBRATION BENCH

EMBEDDED TRANSDUCERS:

Assembly tools calibration process requires a flexible and versatile solution, high quality performance even in production lines. Desoutter Tools is proud to present the Delta Cart, an ergonomic and attractive solution to improve quality in assembly processes.

- Delta Cart offers a wide torque range since it can be configured up to 4 static transducers to cover from 0.2 Nm to 2 000 Nm (0.15 to 1 475 ft.lb) in a very compact dimensions (510mm width), making the Delta Cart the ideal solution for tool testing in assembly production lines.

- PST High accuracy static transducers with locking system specially designed for pulse tool calibration

- ISO RIG (mandatory over 200Nm) System for torque wrench calibration



Embedded PC equipped with wide 12" color touch screen lets operators to start tool testing in a few seconds and few steps.



Delta Cart includes all adapters, reaction bars and suitable joint simulators. Optional ISO RIG for torque wrench to eliminate operator influence during calibration, reducing efforts for high torque range.

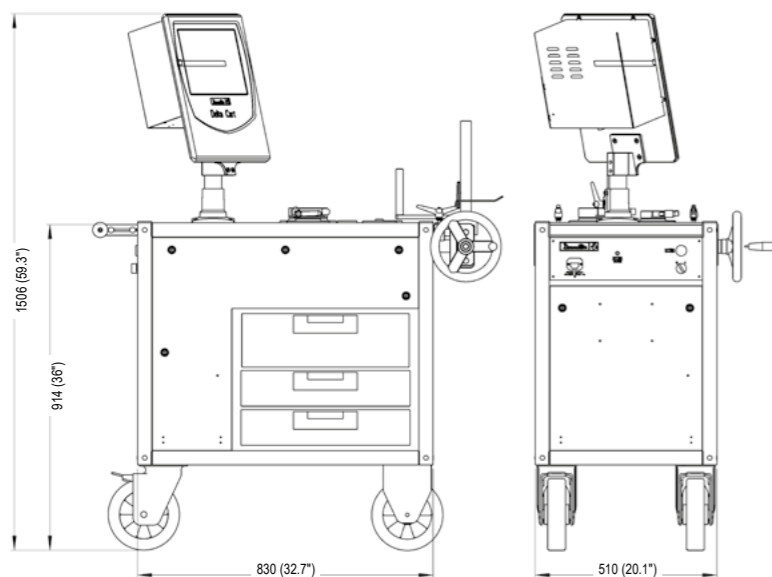

DELTA CART TOOL CALIBRATION



Electric and Pneumatic Nutrunner

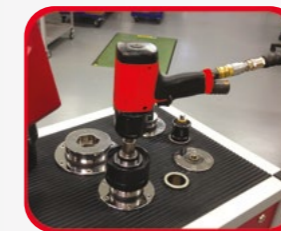

Shut off and non shut off Pulse Tool

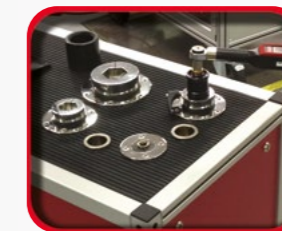

Torque wrench

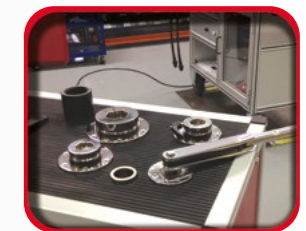

Click wrench

The Delta Cart is able to follow your tools during the complete life span : by performing capacity test (Cm/Cmk) before tool is introduced into production, or monitoring tool performance during production assembly process by performing Statistic Process Control (SPC) test.

FEATURES

- Configurable torque range from 1 Nm to 2 000Nm
- Torque reaction bar and joint simulator included
- External DRT communication for in-line calibration
- Angle Strategy with external DRT5
- CVI2 and CVI3 autocalibration
- Double reading calibration with automatic deviation check

EMBEDDED SOFTWARE WITH LOCAL TOOL DB (SQL SERVER)

- Tools Inventory with calibration status and next calibration date (Excel sheet export)
- Calibration STATUS
- Cm/Cmk Reports
- SPC X/R Charts
- USER Management - login per user

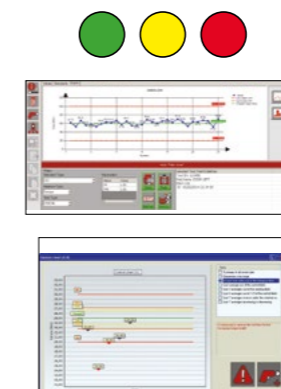

CLIENT - SERVER ARCHITECTURE

- Ideal for > 1 cart management
- All Calibration data always synchronized with unique Server database
- Fast Ethernet communication

ROUTE MANAGEMENT

- Send to Delta Cart just the Tool to be tested

SOFTWARE FEATURES

Torque Wrench, Electric or Pneumatic Nutrunner Test, Pulse Test Cm/Cmk - ISO 3534 ISO 6789 - ISO 5393	Local Test Database up to 30000 Tests - Setting: Nominal Min Max Torque, unit of measure, Test Id, Test Description, Transducer number, Timeout setting Cm/Cmk, min, max, average, sigma Automatic test report
Statistic Control - ISO 8258 Print	X/R Charts for trend control Direct Printing from Delta Cart PC software Certificate export to PDF or XLS Torque/Time or Torque/Angle with external DRT5
Export Curve	External USB N.m - gf.cm - Kgf.cm - kgf.m - ozf.in - lbf.in - lbf.ft
Barcode Configurable for each test Languages	English, French, Italian, German, Russian

ALPHA LOW TORQUE ANALYZER

Dedicated torque analyzers for the setting and static test checks of low torque screwdrivers, either pneumatic or electric.



Embedded Transducer & Battery



TECHNICAL SPECIFICATIONS

Torque Transducer	Embedded
Torque Accuracy	+/-1 % of readings
Tools Testing	Torque Wrench, Nutrunner or Pulse Tools
Statistic	Min. Max, Average, Standard Deviation
Results Storage	1000 + 10 curves with DeltaQC Licenced
Multi-units	N.m, Kg.m, Kg.cm, Oz.in, Lb.in, Lb.ft, N.cm
Display	Red, Green, Blue backlight
Power Supply	Embedded Battery External power supply
Battery Autonomy	Up to 12 hours
Languages	French, English, Spanish, Italian, Deutsch, Portuguese
Software	Free Delta QC Software to export by USB result

ALPHA LOW TORQUE ANALYZER

FEATURES

- Alpha D Series is designed to monitor and collect torque check results from screwdrivers, torque wrenches or click wrenches.
- Ideal to tune the tools thanks to real time statistics on color display and high capacity torque results storage.
- Traceability with included software result acquisition with time stamp, including PDF or XLS reports.
- Three models with embedded transducer to cover torque range from 0,1 to 16 Nm. All models are provided with two included joint simulators to test nutrunner according to different joint stiffness condition.

Backlight RGB color display with acoustic buzzer

Hard & Soft Joint Simulator



MODEL	PART NUMBER
DJS FOR ALPHA_D1 SOFT	615 936 120 0
DJS FOR ALPHA_D1 HARD	615 936 121 0
DJS FOR ALPHA_D5 SOFT	615 936 122 0
DJS FOR ALPHA_D5 HARD	615 936 123 0
DJS FOR ALPHA_D16 SOFT	615 936 124 0
DJS FOR ALPHA_D16 HARD	615 936 125 0
UNIVERSAL POWER SUPPLIER	615 936 143 0

MODEL	PART NUMBER	P. CHARGER	TORQUE RANGE	DEPTH	WIDTH	HEIGHT	WEIGHT
ALPHA 1D	615 935 140 0	110/240V	0.1 - 1	0.88 - 8.85	106	4.17	180 7.09 70 2.76 0.95 2.1
ALPHA 6D	615 935 141 0	110/240V	0.5 - 5	4.42 - 44.25	106	4.17	180 7.09 70 2.76 0.95 2.1
ALPHA 7D	615 935 142 0	110/240V	1.6 - 16	14.1 - 141.6	106	4.17	180 7.09 70 2.76 0.95 2.1

All models are supplied with external power supply, suitable hard and soft joint simulators and Delta QC Software.

QSHIELD - STANDALONE

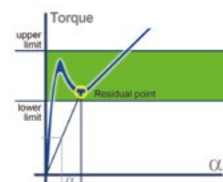

- ISO 6789:2017 compliance
- Quality Strategies
- Joint Analysis
- Delta QC platform software

AUDIT & JOINT ANALYSIS DIGITAL WRENCH

QSHIELD-S SERIES provide a freedom for Quality Operators and Process Engineers to use the wrench in a free mode and independently from production datas: Joint check during audits, conduct Joint analysis on prototypes to or simply retightening mode to secure a joint.

- 5 methods of Residual Torque checks (as per VDI-VDE 2645 part 3).
- Menus are accessible for a versatile usage by a trained staff.
- The vibrating handle (configurable threshold) provides an immediate feedback even in a loud environment of work.
- Results & Curves are stored in the wrench until downloaded on Delta QC (Quality Control Software).



MODEL	PART NUMBER	RANGE		ANGLE	DRIVE		INCLUDED RATCHET	LENGHT WITHOUT RATCHET		LEVER ARM*		WEIGHT	
		Nm	ft.lbs		mm	in.		mm	in.	mm	in.	kg	lb.
Q-SHIELD 30-S	615 935 210 0	3 - 30	2.21 - 22.13	✓	9X12	0.35X0.47	3/8	402	15.83	320	12.6	0.7	1.5
Q-SHIELD 150-S	615 935 211 0	15 - 150	11.06 - 110.6	✓	14X18	0.55X0.71	1/2	418	16.46	342	13.5	0.8	1.7
Q-SHIELD 200-S	615 935 212 0	20 - 200	14.75 - 147.5	✓	14X18	0.55X0.71	1/2	627	24.7	552	21.75	1.6	3.5
Q-SHIELD 350-S	615 221 038 0	35 - 350	25.81 - 258.1	✓	14X18	0.55X0.71	3/4	694	27.33	625.5	24.62	2.6	5.7
Q-SHIELD 400-S	615 935 213 0	40 - 400	29.5 - 295.0	✓	14X18	0.55X0.71	3/4	1028	40.48	960	37.8	3.2	7.0
Q-SHIELD 500-S	615 935 214 0	50 - 500	36.88 - 368.8	✓	21X26	0.82X1.02	3/4	1137	44.77	1100	43.3	5.5	12.1
Q-SHIELD 800-S	615 935 215 0	80 - 800	59.0 - 590.0	✓	DIA 28	DIA 1.1	1	1314	51.74	1362	53.62	6.7	14.7
Q-SHIELD 900-S	615 935 216 0	90 - 900	66.38 - 663.8	✓	DIA 28	DIA 1.1	1	1392	54.8	1440	56.7	8.2	18.0

* Useful length is from Ratchet axis to handle middle.
All models are supplied with box including reversible ratchet with TAG (QShield Batteries supplied separately).



PIC REF	MODEL	PART NUMBER	HEIGHT		LENGTH		WIDTH		WEIGHT	
			mm	in	mm	in	mm	in	gr	lb
A	QSHIELD BATTERY	615 936 500 0	-	-	110	4.33	Ø 22	Ø 8.86	80	0.18
B	BATTERY DOUBLE CHARGER	615 936 461 0	68	2.67	210	8.26	150	5.90	1290	2.84
C	Q-SHIELD 2X ADAPTERS	615 936 533 0	-	-	-	-	-	-	160	0.35
D	WRENCH PROTECTION	615 936 504 0	-	-	-	-	-	-	-	-

DELTAQC SOFTWARE	FREE	LICENSED	ADVANCED
PSET PROGRAMMING	✓	✓	✓
RESULT VIEWER	✓	✓	✓
RESULT EXCEL EXPORT	✓	✓	✓
CURVE VIEWER		✓	✓
RESULT DATABASE			✓

MODEL	PART NUMBER
DELTAQC LICENSED 1 USER	615 927 651 0
DELTAQC LICENSED 5 USERS	615 927 652 0
DELTAQC ADVANCED 1 USER	615 927 653 0
DELTAQC ADVANCED 5 USERS	615 927 654 0

QSHIELD-S STRATEGIES

TECHNICAL SPECIFICATIONS

Standards compliance	ISO 6789:2017 / VDI-VDE 2645-2 & -3
Torque Accuracy	+/-1% of torque reading +/-1 digit from 10 to 100% of nominal torque.
Angle Accuracy	+/-1% from 3°/Sec to 250°/sec
Predefined Pset	250 Psets with T/A defined in Delta QC Software
Batch Count	Up to 99
Results	1000 in memory, last 99 results accessible directly on the wrench display (FIFO) without external PC or software
Curves	25 curves with Delta QC licensed
Quality Audit & Testing Strategies	Residual Torque/Angle Automatic, Residual Peak/Torque, Residual Torque/Angle, Residual Minimum after breakaway, Residual Intersection determination, Residual Gradient change, Residual Loose and Tighten, Yield Point (Joint Analysis), Drag Torque
Tightening Strategies	Torque/Time, Torque & Angle, Torque+Angle CW/CCW Tightenings
Extension Management	Torque and Angle bending correction per Pset
USB Communication	Bi-directional communication to Delta QC Software
RGB Display	Red / Green / Blue backlight
Battery	Li-ion battery
Power Autonomy	10 hours on QShield-S
Multi-Units	N.m, kgf.m, lbf.ft, lbf.in, ozf.ft, ozf.in, kp.m, dN.m
Languages	English, Spanish, German, Portuguese, French, Italian
Software	Free Delta QC Software to define Pset and download results (extended capabilities with Licensed and Advanced versions)

BENEFITS

- Real residual torque value without any special programming or setting from operator
- Save time no PC setting are required
- No risk to release an over loaded fastener as mean value is saved
- Residual value operator independent
- Export data for quality & statistic analysis
- Perfect for fast & accurate pulse tools setting

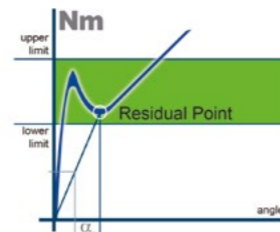

Residual Torque (VDI-VDE 2645-3)

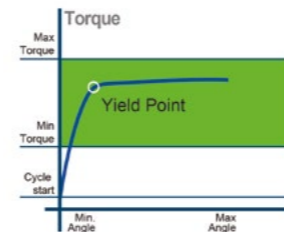

Yield point (Joint Analysis)

OTHER TIGHTENING STRATEGIES ARE ALSO AVAILABLE

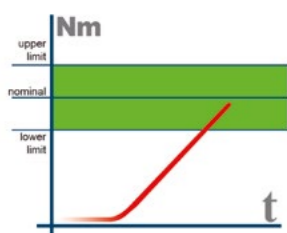

Torque/Time

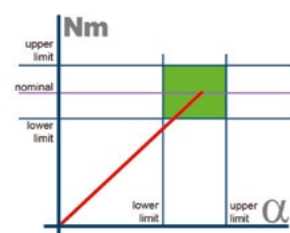

Torque & Angle
Torque + Angle

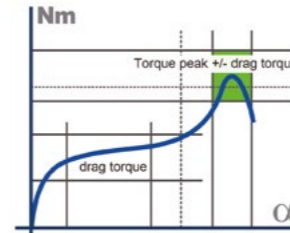

Prevailing torque
automatic compensation

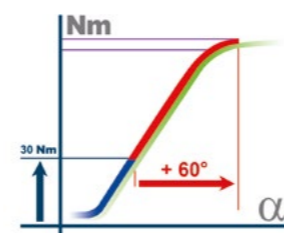

Tightening with torque and
additional angle rotation
(torque + angle)

QUALITY ASSURANCE - BEST PRACTICES

ENSURE QA IN TIGHTENING REQUIRES:

- Initial Tool verification



- Routine residual torque online verification



- Routine & Reactive dynamic online verification



- Routine tool transducer calibration



- Routine plant standard calibration (in ISO/IEC 17025 Accredited laboratories)



- Data retention



IMPORTANT ELEMENTS TO CONSIDER IN SELECTING YOUR QUALITY EQUIPMENTS

- List Torque specifications / Quality Control specifications.
- Classification of your joints (Criticality of assembly operations in the Control Plan).
- Processes for tool testing, joint testing and standard calibration equipment.
- Ensure data is collected, maintained and accessible.

QSHIELD - CONNECTED

RFID TAG End-fittings with automatic recognition for ratio management and/or Pset selection

Standard interchangeable heads and reversible ratchets

New Wrench Protection

New easy pairing & rebalancing

RGB Color display Visual feedback AND a complementary configurable vibration for operator guidance

New Li-Ion Battery 8 hours autonomy on QShield-C

Length independent transducer with double bridge strain gauge to guarantee a tightening result regardless of the position of the operator's hand.

Accuracy of +/-1% on Torque reading value (from 10 to 100% of the nominal torque)

New Gyroscope (Angle 1,2° to 250°/s)

Industrial IoT gateway module

- Dual band (2.4 & 5 Ghz)
- Wi-Fi enterprise security
- Global certification (TLS encryption)

Mini USB port for Configuration, data export to Delta QC software & Calibrations

- ISO 6789:2017 compliance
- Wireless Communication & Easy Pairing
- Real Time reporting & traceability
- Feature Management & rebalancing
- A Unique platform of Multi-Tools on CONNECT allowing Tightening / Rework stations

QSHIELD-C ON CONNECT

QSHIELD-C SERIES is a unique flexible solution to secure safety and quality critical applications on production lines, either requiring the highest precision on both torque and angle, tightening sequences with interchangeable heads, or simply enable assembly in difficult access conditions. It's a step in the evolution of processes to ramp up until production volumes justify investments to semi-automatic or fully automated processes.

Ultimately, it's also accurate and flexible enough to allow a rework from previous stations.



MODEL	PART NUMBER	RANGE		ANGLE	DRIVE		INCLUDED RATCHET	LENGTH WITHOUT RATCHET		LEVER ARM*		WEIGHT	
		Nm	ft.lbs		mm	in.		mm	in.	mm	in.	kg	lb.
Q-SHIELD 30-C	615 935 200 0	3 - 30	2.21 - 22.13	✓	9X12	0.35X0.47	3/8	402	15.83	320	12.6	0.7	1.5
Q-SHIELD 150-C	615 935 201 0	15 - 150	11.06 - 110.6	✓	14X18	0.55X0.71	1/2	418	16.46	342	13.5	0.8	1.7
Q-SHIELD 200-C	615 935 202 0	20 - 200	14.75 - 147.5	✓	14X18	0.55X0.71	1/2	627	24.7	552	21.75	1.6	3.5
Q-SHIELD 350-C	615 221 037 0	35 - 350	25.81 - 258.1	✓	14X18	0.55X0.71	3/4	694	27.33	625.5	24.62	2.6	5.7
Q-SHIELD 400-C	615 935 203 0	40 - 400	29.5 - 295.0	✓	14X18	0.55X0.71	3/4	1028	40.48	960	37.8	3.2	7.0
Q-SHIELD 500-C	615 935 204 0	50 - 500	36.88 - 368.8	✓	21X26	0.82X1.02	3/4	1137	44.77	1100	43.3	5.5	12.1
Q-SHIELD 800-C	615 935 205 0	80 - 800	59.0 - 590.0	✓	DIA 28	DIA 1.1	1	1314	51.74	1362	53.62	6.7	14.7
Q-SHIELD 900-C	615 935 206 0	90 - 900	66.38 - 663.8	✓	DIA 28	DIA 1.1	1	1392	54.8	1440	56.7	8.2	18.0

* Useful length is from Ratchet axis to handle middle. All models are supplied with box including reversible ratchet with TAG (QShield Batteries supplied separately).

PIC REF	MODEL	PART NUMBER	HEIGHT		LENGTH		WIDTH		WEIGHT	
			mm	in	mm	in	mm	in	gr	lb
A	QSHIELD BATTERY	615 936 500 0	-	-	110	4.33	Ø 22	Ø 8.86	80	0.18
B	BATTERY DOUBLE CHARGER	615 936 461 0	68	2.67	210	8.26	150	5.90	1290	2.84
C	Q-SHIELD 2X ADAPTERS	615 936 533 0	-	-	-	-	-	-	160	0.35
D	WRENCH PROTECTION	615 936 504 0	-	-	-	-	-	-	-	-

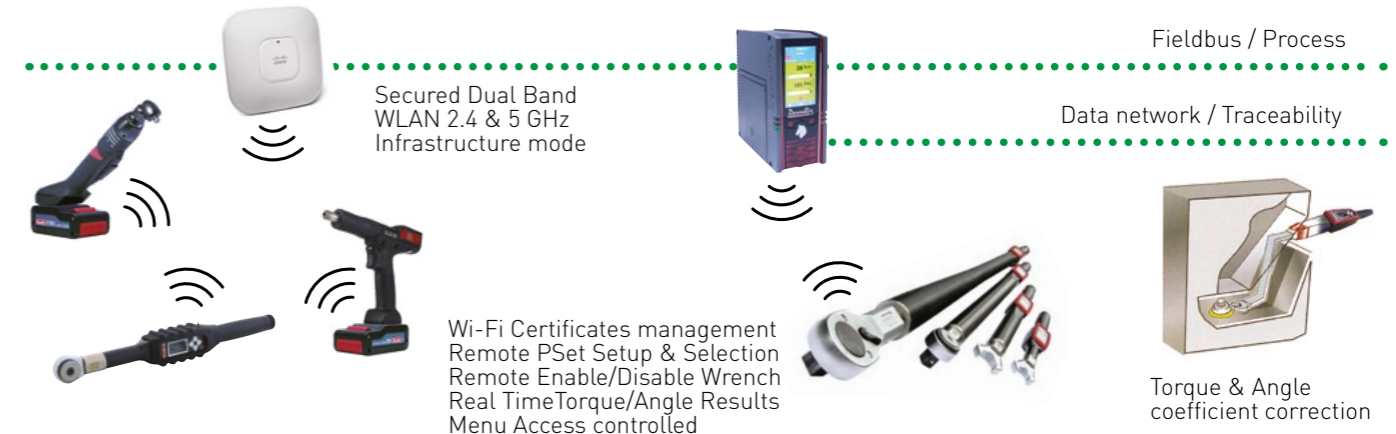

QSHIELD-C STRATEGIES



TORQUE STRATEGY:
Tightening to a Target Torque with a monitoring of the Angle and Torque (OK if both Torque and Angle are within Min/Max)

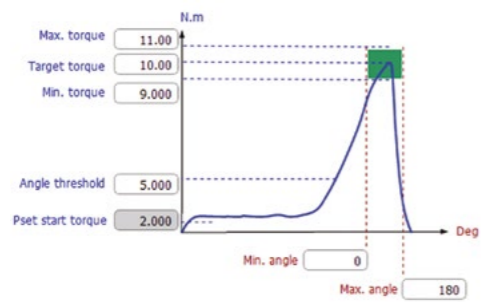

ANGLE STRATEGY:
Tightening to a Target Angle with a monitoring of the Torque and Angle (OK if both Torque and Angle are within Min/Max)

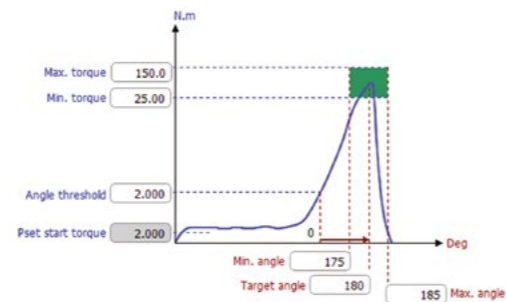

RESIDUAL TORQUE STRATEGY:
Joint check in Production on pre-tightened joints (NOK management)

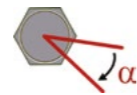
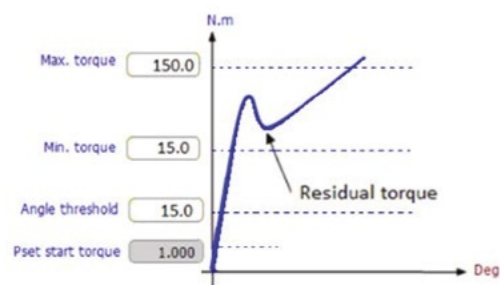

Triple result detection
Residual + Breakaway (B)
+ Peak Torque (P)



BENEFITS

- Accuracy for critical tightenings
- Wide torque range to replace click wrenches
- Production data traceability
- Repair station fastening capability
- Difficult access joints tightening
- Re-hit detection
- Low calibration cost
- Back up tool for safety & quality critical applications



7 TYPICAL SCENARIOS

- 1 Start of production (low quantities - ROI)
- 2 Difficult access conditions
- 3 More accuracy
- 4 Sequence using different end-fittings
- 5 Tighten to angle
- 6 Rework station (Diversity & Uptime)
- 7 PCT Test (Residual torque / Joint check)

DIGITAL WRENCH ACCESSORIES

END FITTINGS WITH EMBEDDED RFID TAG* AND NO TAG



OPEN END - METRIC	TAG	NO TAG
DRIVE 9X12 OPEN END 7 MM	615 936 152 0	615 397 055 0
DRIVE 9X12 OPEN END 8 MM	615 936 153 0	615 397 056 0
DRIVE 9X12 OPEN END 9 MM	615 936 154 0	615 397 057 0
DRIVE 9X12 OPEN END 10 MM	615 936 155 0	615 397 058 0
DRIVE 9X12 OPEN END 11 MM	615 936 156 0	615 397 059 0
DRIVE 9X12 OPEN END 12 MM	615 936 157 0	615 397 060 0
DRIVE 9X12 OPEN END 13 MM	615 936 158 0	615 397 061 0
DRIVE 9X12 OPEN END 14 MM	615 936 159 0	615 397 062 0
DRIVE 9X12 OPEN END 15 MM	615 936 160 0	615 397 063 0
DRIVE 9X12 OPEN END 16 MM	615 936 161 0	615 397 064 0
DRIVE 9X12 OPEN END 17 MM	615 936 162 0	615 397 065 0
DRIVE 9X12 OPEN END 18 MM	615 936 163 0	615 397 066 0
DRIVE 9X12 OPEN END 19 MM	615 936 164 0	615 397 067 0
DRIVE 14X18 OPEN END 13 MM	615 936 194 0	615 397 131 0
DRIVE 14X18 OPEN END 14 MM	615 936 195 0	615 397 132 0
DRIVE 14X18 OPEN END 15 MM	615 936 196 0	615 397 133 0
DRIVE 14X18 OPEN END 16 MM	615 936 197 0	615 397 134 0
DRIVE 14X18 OPEN END 17 MM	615 936 198 0	615 397 135 0
DRIVE 14X18 OPEN END 18 MM	615 936 199 0	615 397 136 0
DRIVE 14X18 OPEN END 19 MM	615 936 200 0	615 397 137 0
DRIVE 14X18 OPEN END 21 MM	615 936 201 0	615 397 138 0
DRIVE 14X18 OPEN END 22 MM	615 936 202 0	615 397 139 0
DRIVE 14X18 OPEN END 24 MM	615 936 203 0	615 397 140 0
DRIVE 14X18 OPEN END 27 MM	615 936 204 0	615 397 141 0
DRIVE 14X18 OPEN END 30 MM	615 936 205 0	615 397 142 0
DRIVE 14X18 OPEN END 32 MM	615 936 206 0	615 397 143 0
DRIVE 14X18 OPEN END 34 MM	615 936 207 0	615 397 144 0



RING BOX END - METRIC	TAG	NO TAG
DRIVE 9X12 RING BOX END 7 MM	615 936 165 0	615 397 078 0
DRIVE 9X12 RING BOX END 8 MM	615 936 166 0	615 397 079 0
DRIVE 9X12 RING BOX END 10 MM	615 936 167 0	615 397 080 0
DRIVE 9X12 RING BOX END 11 MM	615 936 168 0	615 397 081 0
DRIVE 9X12 RING BOX END 12 MM	615 936 169 0	615 397 082 0
DRIVE 9X12 RING BOX END 13 MM	615 936 170 0	615 397 083 0
DRIVE 9X12 RING BOX END 14 MM	615 936 171 0	615 397 084 0
DRIVE 9X12 RING BOX END 15 MM	615 936 172 0	615 397 085 0
DRIVE 9X12 RING BOX END 16 MM	615 936 173 0	615 397 086 0
DRIVE 9X12 RING BOX END 17 MM	615 936 174 0	615 397 087 0
DRIVE 9X12 RING BOX END 18 MM	615 936 175 0	615 397 088 0
DRIVE 9X12 RING BOX END 19 MM	615 936 176 0	615 397 089 0
DRIVE 9X12 RING BOX END 21 MM	615 936 177 0	615 397 090 0
DRIVE 9X12 RING BOX END 22 MM	615 936 178 0	615 397 091 0
DRIVE 14X18 RING BOX END 13 MM	615 936 208 0	615 397 173 0
DRIVE 14X18 RING BOX END 14 MM	615 936 209 0	615 397 174 0
DRIVE 14X18 RING BOX END 15 MM	615 936 210 0	615 397 175 0
DRIVE 14X18 RING BOX END 16 MM	615 936 211 0	615 397 176 0
DRIVE 14X18 RING BOX END 17 MM	615 936 212 0	615 397 177 0
DRIVE 14X18 RING BOX END 18 MM	615 936 213 0	615 397 178 0
DRIVE 14X18 RING BOX END 19 MM	615 936 214 0	615 397 179 0
DRIVE 14X18 RING BOX END 21 MM	615 936 215 0	615 397 180 0
DRIVE 14X18 RING BOX END 22 MM	615 936 216 0	615 397 181 0
DRIVE 14X18 RING BOX END 24 MM	615 936 217 0	615 397 182 0
DRIVE 14X18 RING BOX END 27 MM	615 936 218 0	615 397 183 0
DRIVE 14X18 RING BOX END 30 MM	615 936 219 0	615 397 184 0
DRIVE 14X18 RING BOX END 32 MM	615 936 220 0	615 397 185 0
DRIVE 14X18 RING BOX END 34 MM	615 936 221 0	615 397 186 0
DRIVE 14X18 RING BOX END 36 MM	615 936 222 0	615 397 187 0
DRIVE 14X18 RING BOX END 41 MM	615 936 223 0	615 397 188 0



FLARED END - METRIC	TAG	NO TAG
DRIVE 9X12 FLARED END 10 MM	615 936 179 0	615 397 103 0
DRIVE 9X12 FLARED END 11 MM	615 936 180 0	615 397 104 0
DRIVE 9X12 FLARED END 12 MM	615 936 181 0	615 397 105 0
DRIVE 9X12 FLARED END 13 MM	615 936 182 0	615 397 106 0
DRIVE 9X12 FLARED END 14 MM	615 936 183 0	615 397 107 0
DRIVE 9X12 FLARED END 16 MM	615 936 184 0	615 397 108 0
DRIVE 9X12 FLARED END 17 MM	615 936 185 0	615 397 109 0
DRIVE 9X12 FLARED END 18 MM	615 936 186 0	615 397 110 0
DRIVE 9X12 FLARED END 19 MM	615 936 187 0	615 397 111 0
DRIVE 9X12 FLARED END 21 MM	615 936 188 0	615 397 112 0
DRIVE 9X12 FLARED END 22 MM	615 936 189 0	615 397 113 0
DRIVE 9X12 FLARED END 24 MM	615 936 190 0	615 397 114 0

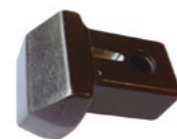

BLANK END	TAG	NO TAG
DRIVE 9X12 BLANK END	615 936 228 0	615 397 130 0
DRIVE 14X18 BLANK END	615 936 226 0	615 397 203 0
DRIVE 21X26 BLANK END	615 936 444 0	615 936 443 0

*These accessories fit QShield and Delta wrenches.

DIGITAL WRENCH ACCESSORIES

END FITTINGS WITH EMBEDDED RFID TAG* AND NO TAG



OPEN END - INCHES	TAG	NO TAG
DRIVE 9X12 OPEN END 1/4"	615 936 229 0	615 397 069 0
DRIVE 9X12 OPEN END 5/16"	615 936 230 0	615 397 070 0
DRIVE 9X12 OPEN END 3/8"	615 936 231 0	615 397 071 0
DRIVE 9X12 OPEN END 7/16"	615 936 232 0	615 397 072 0
DRIVE 9X12 OPEN END 1/2"	615 936 233 0	615 397 073 0
DRIVE 9X12 OPEN END 9/16"	615 936 234 0	615 397 074 0
DRIVE 9X12 OPEN END 5/8"	615 936 235 0	615 397 075 0
DRIVE 9X12 OPEN END 11/16"	615 936 236 0	615 397 076 0
DRIVE 9X12 OPEN END 3/4"	615 936 237 0	615 397 077 0
DRIVE 14X18 OPEN END 7/16"	615 221 008 0	615 397 145 0
DRIVE 14X18 OPEN END 1/2"	615 221 009 0	615 397 146 0
DRIVE 14X18 OPEN END 9/16"	615 221 010 0	615 397 147 0
DRIVE 14X18 OPEN END 5/8"	615 221 011 0	615 397 148 0
DRIVE 14X18 OPEN END 11/16"	615 221 012 0	615 397 149 0
DRIVE 14X18 OPEN END 3/4"	615 221 013 0	615 397 150 0
DRIVE 14X18 OPEN END 13/16"	615 221 014 0	615 397 151 0
DRIVE 14X18 OPEN END 7/8"	615 221 015 0	615 397 152 0
DRIVE 14X18 OPEN END 15/16"	615 221 016 0	615 397 153 0
DRIVE 14X18 OPEN END 1"	615 221 017 0	615 397 154 0
DRIVE 14X18 OPEN END 1,1/8"	615 221 018 0	615 397 172 0



RING BOX END - INCHES	TAG	NO TAG
DRIVE 9X12 RING BOX END 1/4"	615 936 238 0	615 397 092 0
DRIVE 9X12 RING BOX END 5/16"	615 936 239 0	615 397 093 0
DRIVE 9X12 RING BOX END 3/8"	615 936 240 0	615 397 094 0
DRIVE 9X12 RING BOX END 7/16"	615 936 241 0	615 397 095 0
DRIVE 9X12 RING BOX END 1/2"	615 936 242 0	615 397 096 0
DRIVE 9X12 RING BOX END 9/16"	615 936 243 0	615 397 097 0
DRIVE 9X12 RING BOX END 5/8"	615 936 244 0	615 397 098 0
DRIVE 9X12 RING BOX END 11/16"	615 936 245 0	615 397 099 0
DRIVE 9X12 RING BOX END 3/4"	615 936 246 0	615 397 100 0
DRIVE 9X12 RING BOX END 13/16"	615 936 247 0	615 397 101 0
DRIVE 9X12 RING BOX END 7/8"	615 936 248 0	615 397 102 0
DRIVE 14X18 BOX END 1/2"	615 221 019 0	615 397 189 0
DRIVE 14X18 BOX END 9/16"	615 221 020 0	615 397 190 0
DRIVE 14X18 BOX END 5/8"	615 221 021 0	615 397 191 0
DRIVE 14X18 BOX END 11/16"	615 221 022 0	615 397 192 0
DRIVE 14X18 BOX END 3/4"	615 221 023 0	615 397 193 0
DRIVE 14X18 BOX END 13/16"	615 221 024 0	615 397 194 0
DRIVE 14X18 BOX END 7/8"	615 221 025 0	615 397 195 0
DRIVE 14X18 BOX END 15/16"	615 221 026 0	615 397 196 0
DRIVE 14X18 BOX END 1"	615 221 027 0	615 397 197 0



FLARED END - INCHES	TAG	NO TAG
DRIVE 9X12 FLARED END 3/8"	615 221 001 0	615 397 115 0
DRIVE 9X12 FLARED END 7/16"	615 221 002 0	615 397 116 0
DRIVE 9X12 FLARED END 1/2"	615 221 003 0	615 397 117 0
DRIVE 9X12 FLARED END 9/16"	615 221 004 0	615 397 118 0
DRIVE 9X12 FLARED END 5/8"	615 221 005 0	615 397 119 0
DRIVE 9X12 FLARED END 11/16"	615 221 006 0	615 397 120 0
DRIVE 9X12 FLARED END 3/4"	615 221 007 0	615 397 121 0



REVERSIBLE RATCHET	TAG	NO TAG
DRIVE 9X12 REVERSIBLE RATCHET 1/4"	615 936 191 0	615 397 125 0
DRIVE 9X12 REVERSIBLE RATCHET 3/8"	615 936 192 0	615 397 126 0
DRIVE 9X12 REVERSIBLE RATCHET 1/2"	615 936 193 0	615 397 127 0
DRIVE 14X18 REVERSIBLE RATCHET 1/2"	615 936 224 0	615 397 200 0
DRIVE 14X18 REVERSIBLE RATCHET HD 3/4"	615 936 440 0	615 936 439 0
DRIVE 21X26 REVERSIBLE RATCHET 3/4"	615 936 442 0	615 936 441 0
DRIVE Ø 28 REVERSIBLE RATCHET 1"	615 936 227 0	615 397 204 0



BITS HOLDER	TAG	NO TAG
DRIVE 9X12 BITS HOLDER 1/4"	615 221 028 0	615 397 128 0
DRIVE 9X12 BITS HOLDER 5/16"	615 221 029 0	615 397 129 0
DRIVE 14X18 BITS HOLDER 5/16"	615 221 030 0	615 397 202 0



REVERSIBLE RATCHET	TAG	NO TAG
DRIVE 9X12 FIXED SQUARE DRIVE 1/4"	-	615 397 122 0
DRIVE 9X12 FIXED SQUARE DRIVE 3/8"	-	615 397 123 0
DRIVE 9X12 FIXED SQUARE DRIVE 1/2"	-	615 397 124 0
DRIVE 14X18 FIXED SQUARE DRIVE 1/2"	-	615 397 198 0
DRIVE 14X18 FIXED SQUARE DRIVE 3/4"	-	615 397 199 0

*These accessories fit QShield and Delta wrenches.

More Than Productivity