

Desoutter



Industrial Tools



RAPID

— Desoutter

The Screw Feeding System

BOOST YOUR
FLEXIBILITY

BOOST YOUR
UPTIME

BOOST YOUR
PRODUCTIVITY

More Than Productivity



RAPID

THE SCREW FEEDING SYSTEM

FULLY COMPATIBLE WITH
DESOUTTER SCREW DRIVES
AND CONTROLLERS

ACCESSORIES ON MODULES;

- Escapement monitor
- Pneumatic panel
- Screw level detector
- Washer hammer
- E-lock function
- Switch and indicator

ACCESSORIES ON MODULES;

- Distributor
- Particle cleaner
- Hopper
- Presenter
- Feed hose
- External controller

OPTIONAL DRT/ ONLINE
CALIBRATION FUNCTION

STEP FEEDER OR
BOWL FEEDER

OPTIONAL
PNEUMATIC PANEL

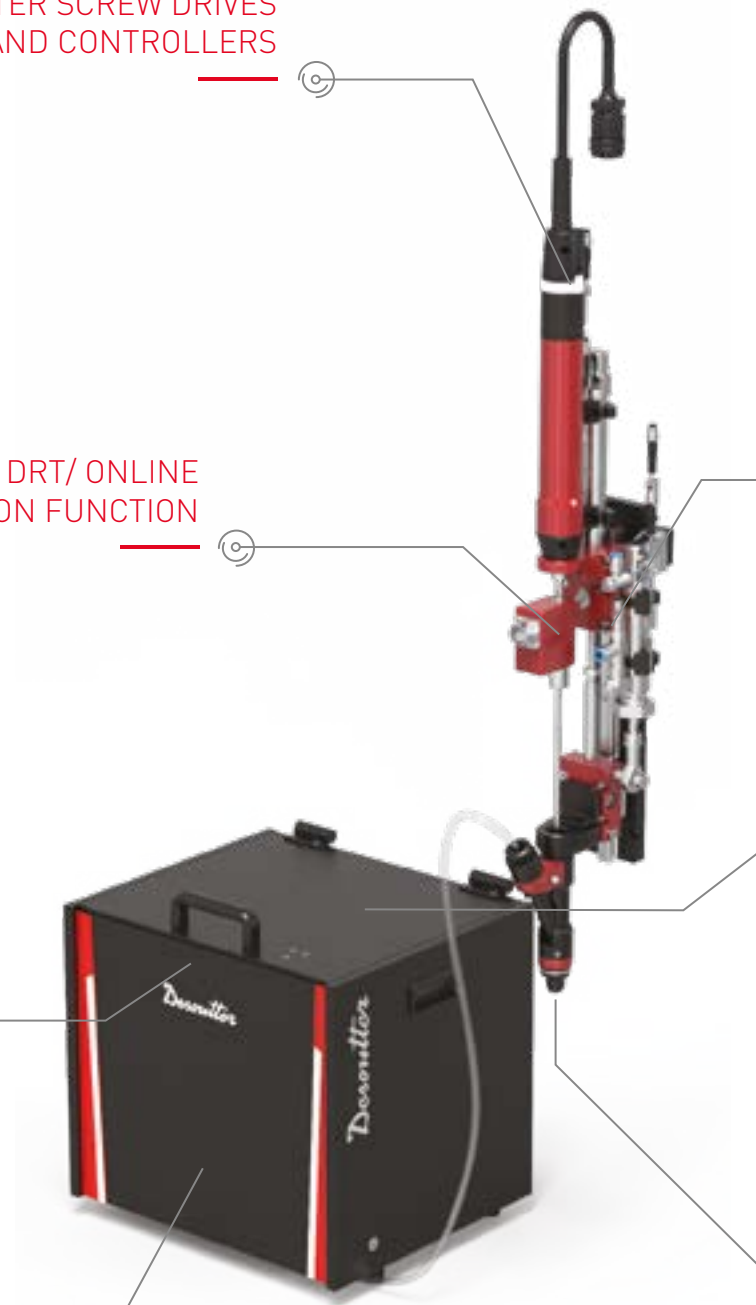



COMPREHENSIVE
RANGE OF
ACCESSORIES

MULTIPLE STROKE MODULE
OPTIONS INCLUDING AUTO-
FEEDING, VACUUM VERSION
FOR HARD-TO REACH
POINTS AND PICK & PLACE.

CE CERTIFIED

MULTIPLE TYPES OF
LOADING HEADS WHICH
FIT ALL TIGHTENING
DIRECTIONS

BOOST YOUR FLEXIBILITY

- ▶ STANDARD MODULAR SYSTEM WHICH CAN BE SPECIFICALLY SELECTED BASED ON AN INDIVIDUAL APPLICATION.
- ▶ WIDE-RANGE OF ACCESSORIES TO STRENGTHEN SYSTEM TOPOLOGY FUNCTIONALITY
- ▶ TRACEABLE MANUALS AND PRODUCT INFORMATION READILY AVAILABLE ON THE DIGITAL TWIN PLATFORM

BOOST YOUR UPTIME

- ▶ MARKET-LEADING SUPPLIERS USING GLOBALLY AVAILABLE INDUSTRIAL MECHANICAL AND ELECTRICAL PARTS.
- ▶ RIGOROUS VALIDATION TESTS OF 5,000 CYCLES FOR EVERY SYSTEM, WHICH ENSURES CONSISTENT QUALITY.
- ▶ ERROR-PROOF METHODS TO REDUCE THE RISK OF A POTENTIAL SCREW JAM.

BOOST YOUR PRODUCTIVITY

- ▶ PERFECT COMPATIBILITY WITH DESOUTTER SCREW DRIVERS AND CONTROLLERS.
- ▶ AUTOMATIC SYSTEM ENABLES A SIGNIFICANTLY IMPROVED CYCLE TIME COMPARED WITH THE MANUAL OPERATION.
- ▶ WELL-PROOFED DESIGN WHICH QUICKLY RESETS IN THE EVENT OF A SCREW JAM PLUS IT ENABLES EASY SERVICE MAINTENANCE, BOTH RESULT IN LESS DOWNTIME.

HOW SCREW FEEDING SYSTEMS ARE BORN?

Automation is a trend that has widely affected the manufacturing industry. This development includes screw feeding systems which now supersede traditional manually-operated tightening stations. This, together with fast-growing robot and electrical screw driver technology, a tightening station's performance, production capacity, and quality control has reached a new level. We are seeing more and more customers using screw feeding system which enables them to:

- ▣ Improve takt time;
- ▣ Achieve higher repeatability;
- ▣ Gain an increased automation level;
- ▣ Avoid dropping screws inside the product;
- ▣ Prevent operators using wrong fasteners;

WHAT ARE THE COMMON CHALLENGES?

Every screw feeding system is specifically designed to adapt to different applications, which means relying on the manufacturer. The starting point is always about the application's objective, then finding the solution that will fit the best. Depending on the production line, the screw driver and screw feeding system is crucial to the success of the tightening station. Other times, a slight design change of the screw or product can ease configuration and increase productivity. Challenges we see in the field include:

- ▣ Operational issues due to incorrect system configuration;
- ▣ High system complexity due to lack of accessories;
- ▣ Low reliability due to lack of error-proof measures;
- ▣ Long periods of failure trouble-shooting;

FIND OUR ANSWERS TO THE CHALLENGES, ABOUT:

- ▣ Modularity and adaptability
- ▣ Flexibility
- ▣ Quality and reliability
- ▣ Uptime



WHY WE DEVELOP RAPID?

We know the value and difference a screw feeding system can be to the success of a tightening process and the overall performance of the final assembly.

As an evolution to our existing product range, the natural next step was our own screw feeding system. Introducing RAPID. As a integrated solution with our screw driver and controller, the trio improves flexibility of project management, and the entire tightening process.

The combination provides increased productivity and reduced downtime.



With RAPID, we provide three types of **tightening modules** and two types of feeders:

AUTOMATIC STATION AUTO-FEEDING



Screws are blown through the feed hose to the loading head

AUTOMATIC STATION PICK & PLACE



Screws are automatically picked up by the vacuum tube and placed to the tightening point

HAND-HELD STATION PICK & PLACE



Screws are manually picked by the vacuum tube, placed to the tightening point and then start tightening.

STEP FEEDER



BOWL FEEDER



BOWL FEEDER

- Fill volume: 0.4L, 1.0L or 3.0L
- Simple structure and easy maintenance



STEP FEEDER

- Fill volume: 2.0L or 5.0L
- Reduced friction, particles and noise



STRUCTURE

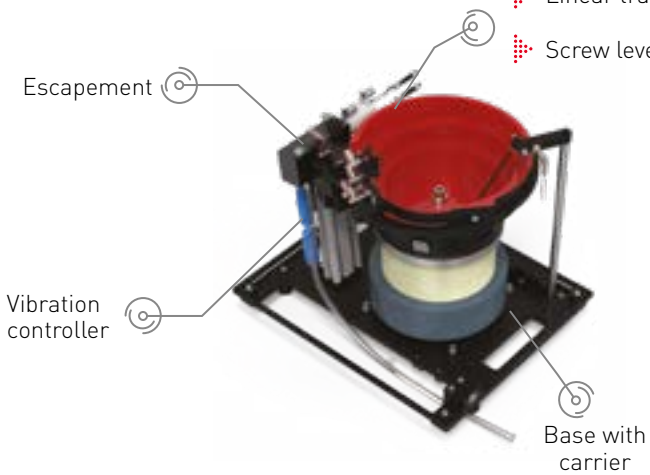

- Container that includes:
- Linear rail
- Linear track sensor
- Screw level indicator

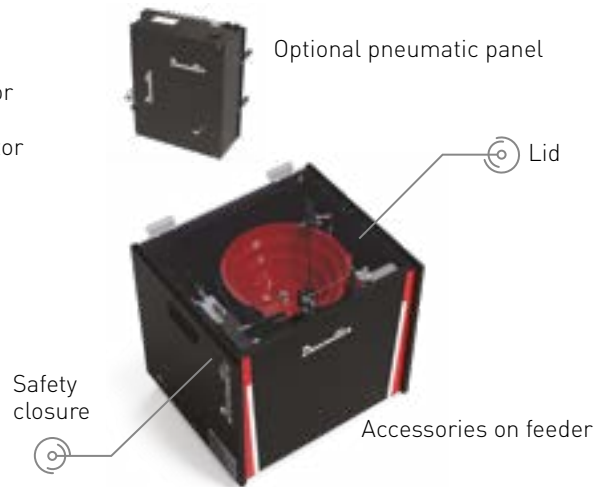

CONTAINER AND LINEAR RAIL



LINEAR RAIL AND ESCAPEMENT



ALL COMPATIBLE WITH DESOUTTER STANDARD SCREWDRIVERS!

AUTOMATIC STATION AUTO-FEEDING

- With or without Z-axis head stroke;
- Vacuum option for hard-to-reach point;
- Male and female screw recess;
- Best cycle time;
- All tightening directions;



S1

S2

VS1/B

VS2/B

VS2/S

AUTOMATIC STATION PICK& PLACE

- Single or double stroke;
- VP0 on your own Z-axis stroke;
- Wide range of screws;
- Best cost for hard-to-reach points;
- Compact and light weight;

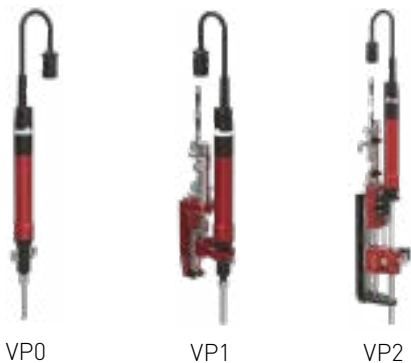

VP0

VP1

VP2

HAND-HELD STATION PICK& PLACE

- VP0 uses for hand-held station;
- Ergonomic design with D53



VP0

"SWIVEL" LOADING HEAD



Stroke module that includes:

- Pneumatic cylinders;
- Screw bit;
- Vacuum tube;
- Vacuum module;
- Guide rail

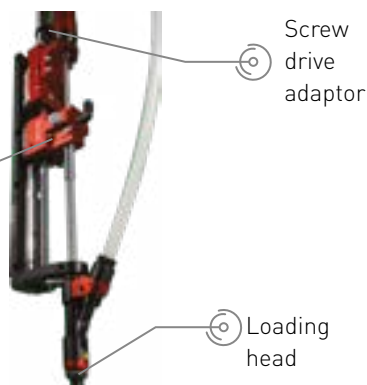

Screw drive adaptor

Loading head

MODULARITY AND ADAPTABILITY

The beauty of RAPID is the ability to select its various modules specifically to fit each individual application. The modular mix is entirely custom to precise customer needs.

The Desoutter engineering team works in collaboration with its customers to determine the best fit, based on various production environments, product specifications, and objectives.

Z-AXIS HEAD STROKE

RAPID provides two types of loading head stroke - with or without loading head approach to tightening points.

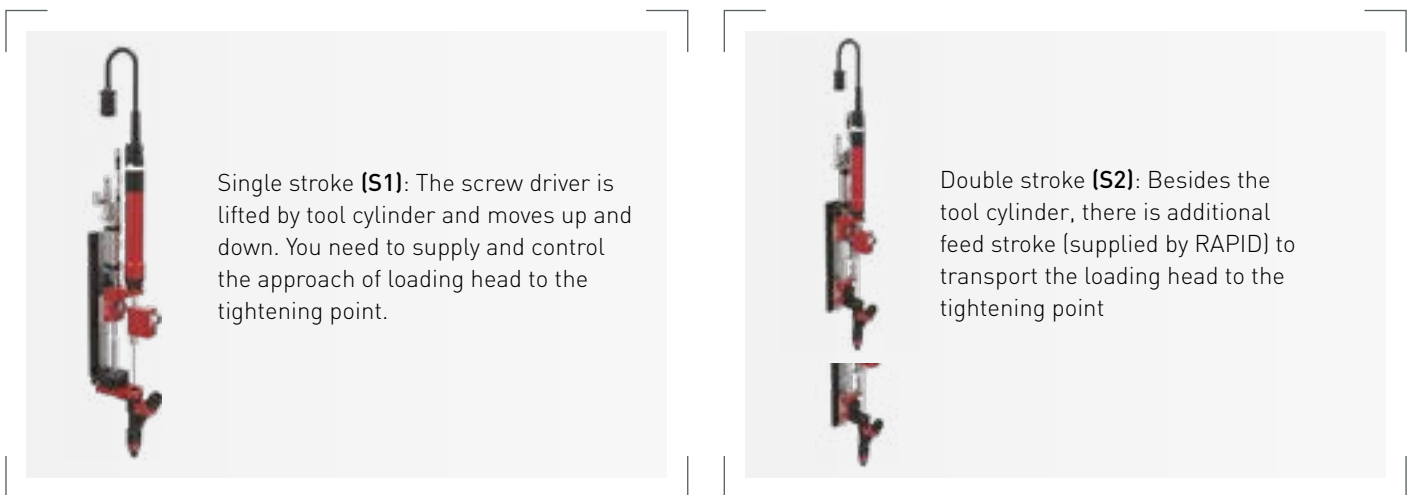

HARD-TO-REACH POINTS:

These maybe due to the interference between the jaws and your product, it is not possible for the loading head directly approach to the tightening point. In this case, RAPID provides vacuum types **(VS1/B AND VS2/S)** for both male and female recess screws to avoid interference.

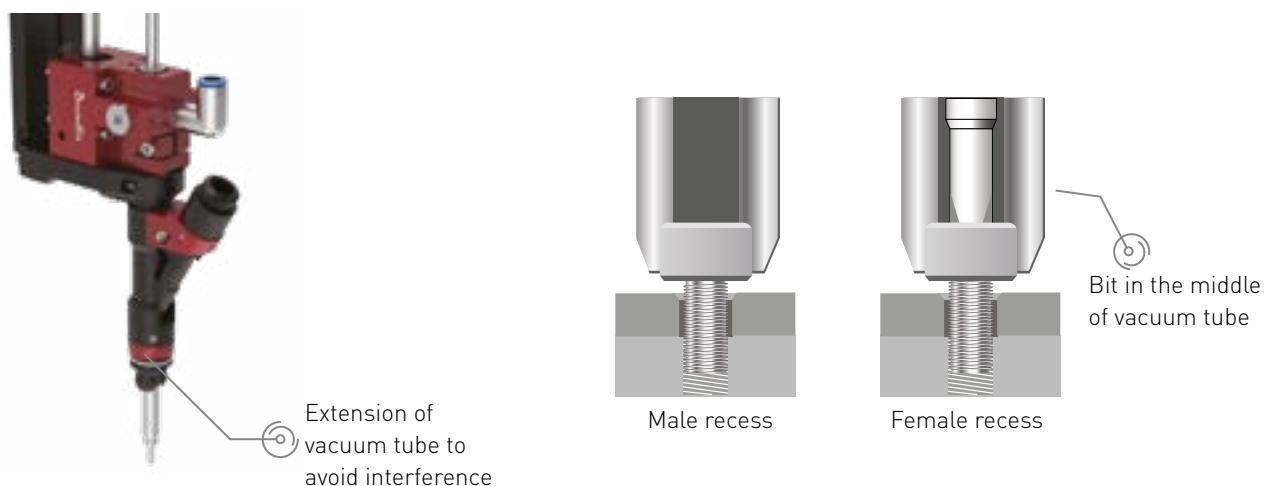

EXTREME HARD-TO-REACH:

If the thickness of vacuum tube may also has interference. RAPID also has solution **(VS2/B)**: the diameter of vacuum tube equals to the screw head diameter.

In this case, it might also make sense to proactively consider pick& place types. The diameter of vacuum tube also equals to the screw head diameter.

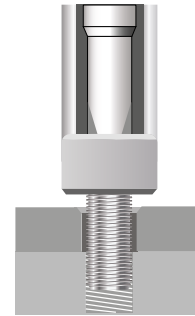

HORIZONTAL OR BOTTOM-UP DIRECTION:

it is no problem for RAPID with the feature of air-holding function on the loading head.



PICK& PLACE TYPES: BEST-FIT TO YOUR REQUEST



VP0



VP1



VP2

- ▀ Without Z-axis provided, VP0 is designed to be manually used or to be fitted on Z-axis supplied by you;
- ▀ With Z-axis provided, VP1 need to push on customer part to tighten;
- ▀ With Z-axis provided and additional stroke, VP2 can tighten the screw without pushing on your part.

FLEXIBILITY

Flexibility provides freedom! RAPID's specifically **key stand-alone accessories** enables best-fit build topology based on a variety of factors including, cycle time, product design and production line layout.

SCREWS DISTRIBUTING:

Multiple number of tightening modules from a single feeder

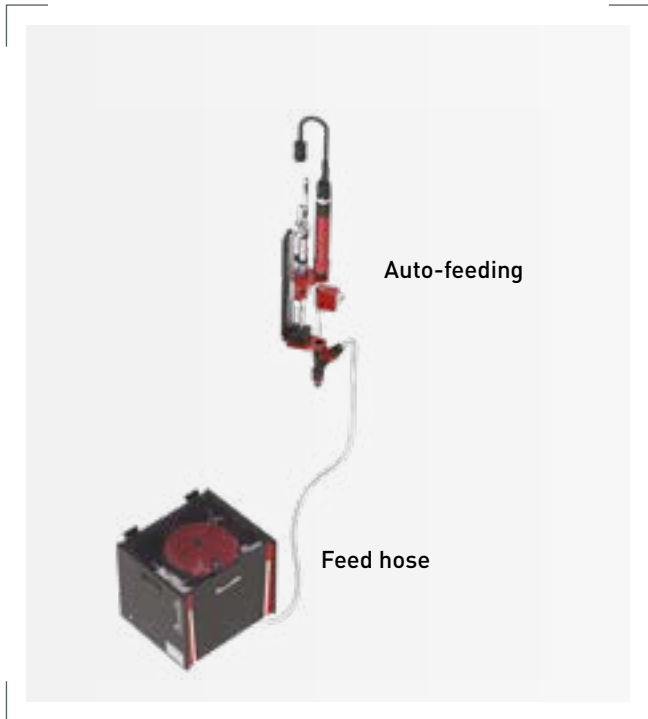

SCREWS MIXING:

Compatibility to mix multiple screw types, please consult Desoutter engineering team for mix-ability check

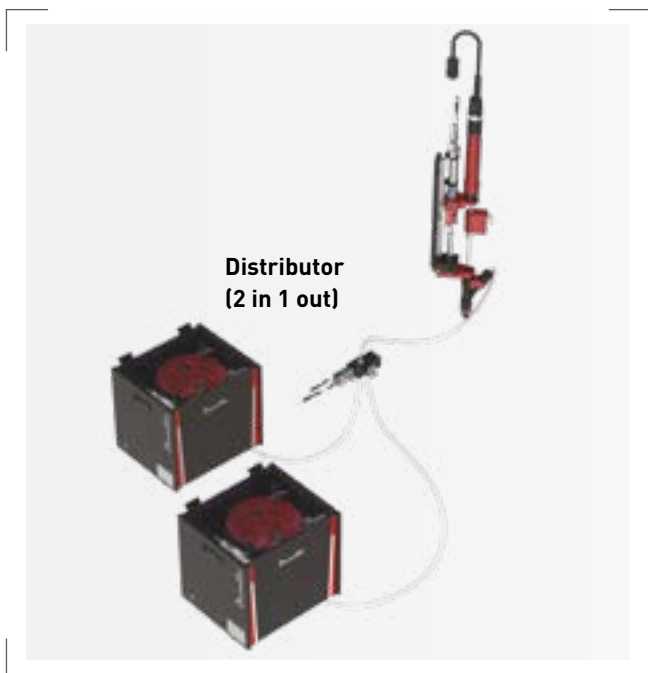

SCREWS DISTRIBUTING & MIXING:



PICK & PLACE from internal picking escapement

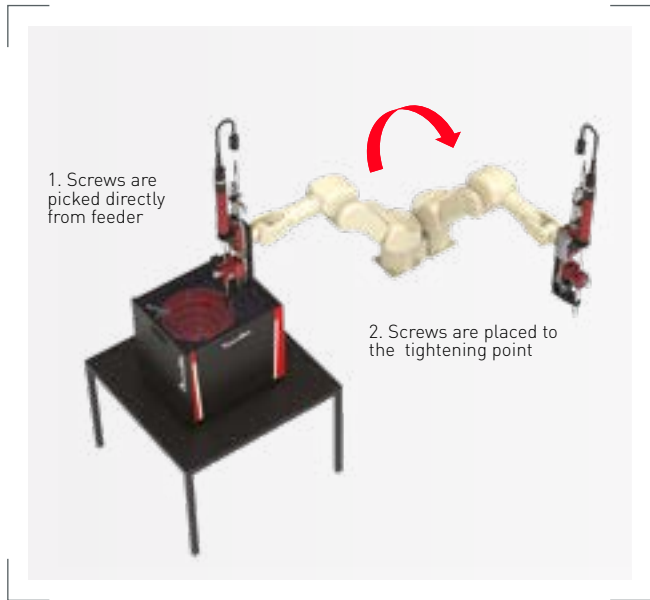

COMBINED AUTO-FEEDING and **PICK& PLACE** from external presenter with screw distributing

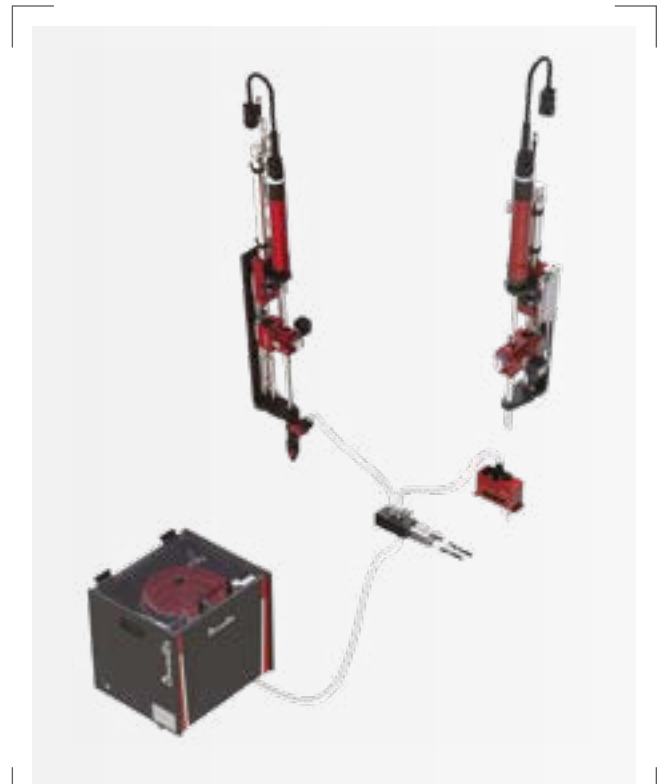

COMBINED AUTO-FEEDING and **PICK& PLACE** from external presenter - The movement distance of robot is saved.

PARTICLE CLEANING in process

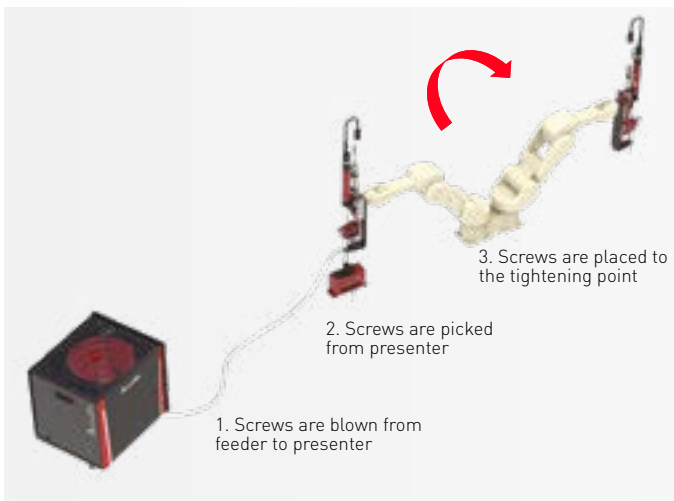
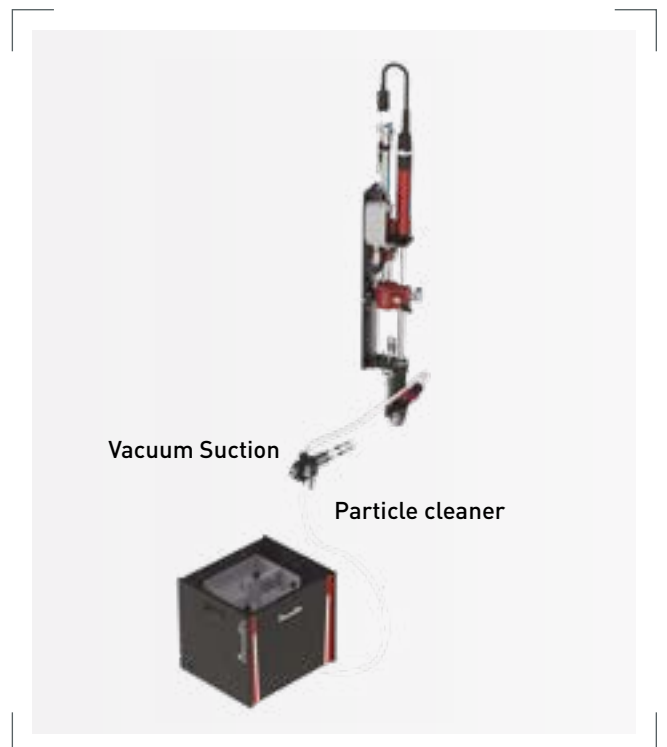

ADDITIONAL VOLUME of screw storage



QUALITY AND RELIABILITY

Quality and Reliability is always the highest priority. From working with market-leading suppliers, to carrying out better-than-standard validation tests of every system, the Desoutter production process is guided by the promise of delivering consistently dependable product.

○ ERROR-PROOF DESIGNS are also embedded in the product by using redundant sensors, but also our experience in configuration.

OPTIONAL ACCESSORIES:

	REDUNDANT SENSOR	USAGE	ERROR PROOF FUNCTION
1	Vacuum sensor	Optional for vacuum type	Check whether vacuum is correctly built up. In case of screw dropping, the sensor should send alert signal.
2	Depth sensor	Optional	Ensure the tool cylinder has correct stroke for tightening, through analogue signal.
3	Search position sensor	Default for male recess screw	Ensure the screw is correctly engaged by the bit.
4	DRT Function	Optional	Tool torque online calibration
5	Overload ejector	Optional	Avoid the overload of screws when the rail is full by air blowing.
6	Escapement sensor	Escapement sensor	Ensure the screw presence in the escapement.
7	Screw hammer	Optional for screws with washer	Ensure correct alignment of screw and washers, by "knocking" the screw head.
8	E-locker	Optional	Safety closure can only be opened, by sending electrical signal to controller.
9	Screw level monitor	Default	Detect the screw level in container and send signal if screws are running out.
10	Feed hose sensor	Default	Check the screw presence in the feed hose.



DESIGN DETAILS OF TIGHTENING MODULE:

2. The self-lock function means both the operators and the customer product is protected in an instance where the air or power is accidentally switched off.

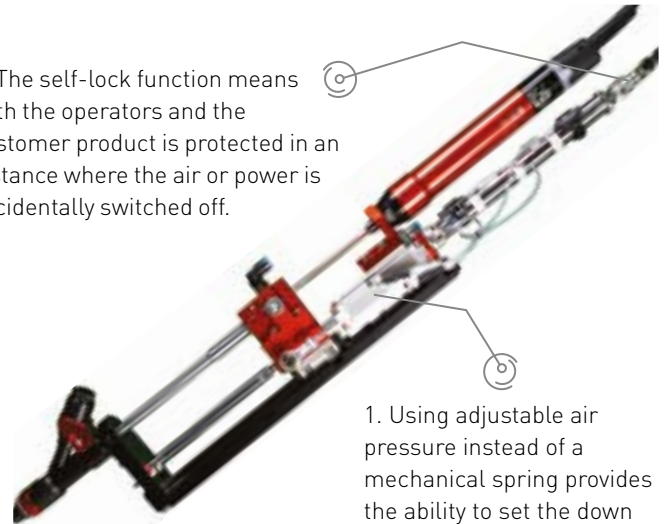

1. Using adjustable air pressure instead of a mechanical spring provides the ability to set the down force, ensuring protection of the customer product.

DESIGN DETAILS OF FEEDER:

1. The design of the block inside the escapement is the exact same shape as the screw. This means the screw is fully wrapped in the block and therefore released into the feed hose with the lowest jam rate.

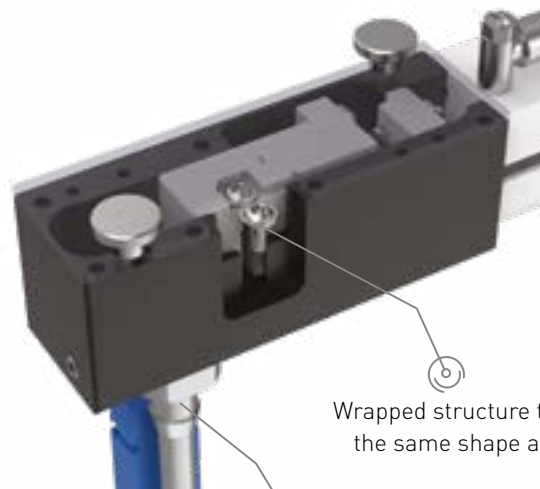

Wrapped structure that is exactly the same shape as the screw

Screw is released into the feed hose

2. The design of safe closure ensure the observation of system operation, easy maintenance and the noise insulation.



Rotative door

Key lock

Closure

Switch and indicator

UPTIME

Uptime is essential the daily operation of any production line. Every minute of downtime means additional cost. Correct configuration from set up, preventative maintenance and the ability to quickly open and reset without any tools, secures and continued harmonious assembly environment.

QUICK BIT CHANGE



Release the bit and turn the loading head to change bit

QUICK LOADING HEAD OPENING



Lift the "swivel" arm to clear screw jam

QUICK BIT CHANGE



Removable lid on the escapement

QUICK LOADING HEAD OPENING



Turn the knob and uplift the upper part of rail

SPECIALLY FIT

Specially Fit to every individual application. There is no one-size-fits-all approach using the **RAPID**. Desoutter engineers work in partnership with customers to understand their need, then provide the exact screw feeding design for them.

It just takes 3 steps:

○ STEP 1: Evaluate the fastener and product design to check whether there is restrictions for screw dimensions or interferences to avoid on the product. So what we need from you is:

- ▣ 2D screw drawing with tolerance
- ▣ 3D product drawing with clearly marked tightening points
- ▣ Torque

○ STEP 2: Understand the production line layout so ensure the correct configuration. Details we will check:

- ▣ Manual or fixture station. And preferred feeding method
- ▣ Control logic, whether it is robot or linear drivers
- ▣ Tightening directions

○ STEP 3: Your specific expectations such as:

- ▣ Cycle time
- ▣ System complexity
- ▣ Environment
- ▣ Additional requests

PLEASE CONTACT US FOR YOUR SPECIFIC REQUESTS, AND **LET'S WORK TOGETHER!**

SCREWFEEDER SERVICE SOLUTIONS

COMMITTED TO OUR CUSTOMERS SUCCESS

START-UP AND COMMISSIONING
HIGH PERFORMANCE, RIGHT FROM THE START!

Smart Start

A fast, high quality installation with no delays that ensures tool accuracy and optimum set-up.

PRODUCTION SUPPORT
ON-SITE SUPPORT TO
HELP BOOST UPTIME AND
PRODUCTIVITY

On-site technicians

Our certified technicians are on hand to quickly solve any on-site issues detected or identify process improvement opportunities.

Certification Training

Develop your technicians' knowledge on troubleshooting and assembly technics
Improve the interaction with Desoutter for efficient remote support.

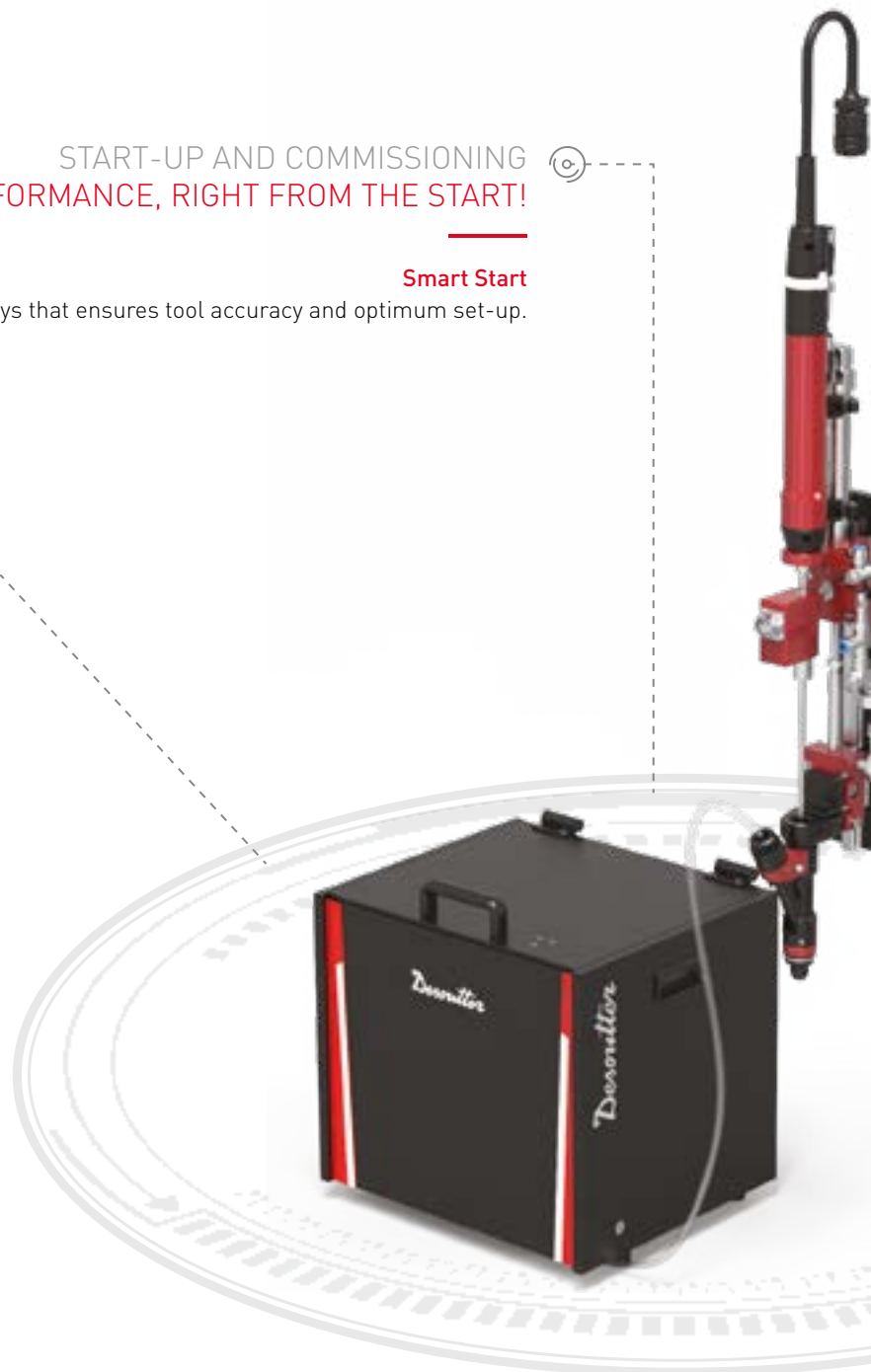

MAINTENANCE SOLUTIONS REDUCE BREAKDOWNS AND EXTEND TOOL LIFE TO BOOST COST EFFICIENCY AND UPTIME

Basic Care

A flexible fixed price preventive maintenance program. Also includes a "condition report".

which recommends a critical stock of parts to avoid future loss of production (based on wear and usage).

BOOST YOUR UPTIME

- ▶ Preventive Maintenance significantly reduces breakdowns and therefore production stops. Uptime is improved.
- ▶ Our experienced on-site technicians know your applications and are on hand to support your team. This allows early detection and resolution of problems. Your uptime is further improved.

BOOST YOUR PRODUCTIVITY

- ▶ Desoutter on-site technicians will coach and support your teams on how to get the best from your equipment. This helps to reduce errors and rework, boosting productivity and quality.
- ▶ Our on-site technicians will help your team to identify and implement process improvements to help you further boost productivity.

BOOST YOUR MAINTENANCE COST EFFICIENCY

- ▶ Preventive Maintenance decreases Breakdowns and extends tool life. This significantly reduces repair and administration costs.

BOOST YOUR FLEXIBILITY

- ▶ All our service solutions can be tailored to your exact needs to ensure maximum flexibility in your production locally or worldwide.

More Than Productivity